

# AMBULANCEMED

AmbulanceMed, who combines technical expertise with the commercial ones and maintains with national/international experience, has led the delivery of thousands of ambulances until today.

## FACTORY - TURKEY

info@ambulancemed.com  
sales@ambulancemed.com

+90 554 969 50 08

DAĞYAKA MAH.2018 SK. NO:23  
AKSAN TİCARET MERKEZİ  
KAHRAMANKAZAN / ANKARA

## FACTORY - DUBAI / UAE

info@ambulancemed.com  
dubai@ambulancemed.com

+971 56 332 6520

X3WR+Q57, Mina Jebel Ali, N506  
Jebel Ali Free Zone, Dubai, UAE

## OFFICE - DUBAI / UAE

info@ambulancemed.com  
dubai@ambulancemed.com

+90 554 969 50 08

Unit no. 604-605, 6F Opal Tower,  
Business Bay/ Dubai/ 128B46  
Registration No: ICC20210433

## OFFICE / INTERNATIONAL

info@ambulancemed.com  
export@ambulancemed.com

+90 554 969 50 08

ATB İş Merkezi, C Blok No: 172  
Yenimahalle / Ankara



Ambulancemed

# MERCEDES BOX TYPE AMBULANCE

Rapid Response. Unmatched Care  
Mercedes Box Type Ambulance.





# **WELCOME** **INTRODUCTION**

Step into the world of AmbulanceMed and experience the epitome of excellence in emergency medical services. Our visionary company proudly presents the exquisitely designed Mercedes-Benz Ambulance, meticulously crafted to redefine the standards of ambulance technology. In this captivating brochure, we invite you to embark on a detailed exploration of the AmbulanceMed masterpiece, where form seamlessly blends with function. Discover the unmatched sophistication of our cutting-edge features, engineered to deliver exceptional patient care and ensure swift, efficient emergency response. Join us as we push the boundaries of innovation and revolutionize the future of ambulance solutions.

## **TABLE OF CONTENT**

You can explore a wealth of information about Box Type within this brochure. Please refer to the following page numbers to find detailed content on each topic

01. Mercedes Box Types Ambulance

---

02. Ambulance Interior

---

03. Table Of Content Goes Here

---

04. Technical Specifications

---

05. Medical Specifications

---

06. Gallery

---

07. Technical Equipments

---

08. Medical Equipments

---

You are about to embark on an informative journey delving deep into the realm of Mercedes-Benz Ambulance

# MERCEDES

## BOX TYPE AMBULANCE

At Ambulancemed, we take great pride in our commitment to transforming Mercedes brand cars into top-of-the-line ambulances, and our latest creation, the Mercedes Box Type Ambulance, is no exception. Manufactured at our state-of-the-art facilities in Dubai and Ankara, this ambulance is designed to provide unparalleled medical care, ensuring optimal sanitary conditions and comfort for both patients and medical professionals.

The heart of the Mercedes Box Type Ambulance lies in its patient compartment, meticulously crafted to offer the highest standards of medical care. We understand the critical nature of emergency medical services, which is why we have ensured ample space for comfortable patient treatment. Every inch of the patient compartment is thoughtfully designed, enabling efficient storage of medical supplies, making them readily accessible during emergencies.

Our ambulance. Medical devices, ambulance connection mounting elements is manufactured as being appropriate with EN 1789+A2 standard.



As a leading manufacturer of ambulances, we are dedicated to serving not only local communities but also extending our reach worldwide. Our ambulances are exported to various countries, ensuring that people around the globe have access to top-tier emergency medical services.

The Mercedes Box Type Ambulance exemplifies Ambulancemed's unwavering commitment to excellence, safety, and innovation. With its unmatched patient care facilities, ergonomic design, efficient lighting and warning systems, and revolutionary WAS assistance systems, it stands at the forefront of the ambulance industry. Together, we strive to elevate emergency medical care and make a significant impact on countless lives across the globe. Choose Ambulancemed - your trusted partner in delivering exceptional emergency medical solutions.

### Efficient Illumination and Special Warning System

- The Mercedes Box Type Ambulance is equipped with an energy-efficient lighting system, providing ample illumination for medical procedures without excessive power consumption. Our special warning system is meticulously designed to garner attention while being conscious of energy use. The combination of effective lighting and warning systems ensures a safe passage through traffic, allowing the ambulance to reach its destination swiftly.

At Ambulancemed, we believe in equipping our ambulances with the latest technologies. The Mercedes Box Type Ambulance comes equipped with the cutting-edge WAS assistance systems, including Door Assist, Multi-Load Assist, SanSafe, and Smart Check Mobile. These state-of-the-art technologies simplify the daily work of the rescue team, streamlining operations and enhancing overall efficiency during emergency responses.

- The Mercedes Box Type Ambulance by Ambulancemed is not only a testament to our dedication to safety and comfort but also a platform to showcase the latest technological medical devices, transforming the landscape of emergency medical care.



Ambulancemed





## AMBULANCE INTERIOR

At AmbulanceMed, we take pride in equipping the ambulance interior with full technological advancements, keeping pace with the demands of the modern era. Our company is dedicated to providing the highest standard of emergency medical services, and we have meticulously designed the ambulance to meet those standards.

The interior is thoughtfully furnished with cutting-edge and tailored equipment, ensuring that it is fully equipped to handle any situation. From advanced medical devices to user-friendly layouts, every detail has been carefully considered to meet the specific needs of emergency responders and patients alike. With AmbulanceMed, you can trust that our technologically advanced ambulance will deliver optimal care when it matters most.





## TECHNICAL AND MEDICAL EQUIPMENT IN *MERCEDES BOX TYPE AMBULANCE*

There are headlamps that work with led on the back and front ceilings providing that looking from outside. These lamps can be controlled from the vehicle driver's cabin; moreover, they have a feature of voiced warning. The back projector, which is based in the headlamp, is able to light the ambulance's main stretcher as long as the ambulance's door has been opened.

Mercedes Box Type Ambulance patient compartment is wide enough to enable transporting and making a medical intervention to two patients at the same time while the one is lying and the other one is sitting. The ambulance's external measures will have the original catalog features which are presented by the manufacturer. There won't be any alteration on the external measures after coming out of the factory. There is no alteration on the vehicle's side and polymids

### *Ambulance Cabin Lighting*

There are 4 led lamps and 2 spot lamps whose control have been made from the vehicle driver's cabin in order to light the cabin. Cabin lighting is fulfilled with a control panel which is located in the vehicle cabinet.

### *Ambulance Digital Electric Panel*

The whole system in the vehicle is controlled with a panel located in the patient cabin, across the sliding door. This panel can be not only digital but also touching.

### *Ambulance Heater*

There is a heater working with a diesel motor or an aqueous system in the patient cabin in order to heat the exterior. There is a door that can be opened among the left and the right side on the right part of the Mercedes Box Type Ambulance compartment in order to enable to bring up and down a patient. Also, there are grip bars on the back doors and left side of the sliding door in order to facilitate to get into the ambulance.

*\*The floor covering of the ambulance is formed as a single piece. It is skidproof. It can be easily cleaned and washed with water. It is antibacterial. It has a high resistant against combustion and structural chemicals.*



## TECHNICAL AND MEDICAL EQUIPMENT IN *MERCEDES BOX TYPE AMBULANCE*

### *-Outdoor Lighting of the Ambulance*

There is outdoor lighting that works simultaneously with 6 blue and red ambulance headlamp on the outside of the ambulance.

### *-Cupboard System of the Mercedes Ambulance*

It is used PVC coating based on foamboard material in the ambulance cabinets and the cabinet systems. Ambulance cupboard covers can be manufactured as orange, blue or white. The materials used in the covers are antibacterial. It is used foamboard material which has a 17mm thickness in the cupboard covers. Foamboard material is manufactured as 1.1k/m<sup>3</sup> intensity. The materials are compatible with 95/28/EC standards, which are non-flammability.

Ambulance coverings are manufactured as one piece. Materials used in the ambulance have ABS principle; in addition, they are antibacterial and fireproof. They can be easily washed. Covering material is manufactured as compatible with EN1789 norms.

### *-Air Conditioning of the Ambulance*

The ambulance has a split air conditioning in order to cool the patient cabinet. Fuel consumption is less than one liter in an hour. Its weight is less than 10 kilograms. Air conditioning of the ambulance is used in different capacities depending on the geographical regions.

### *-Stretcher Platform of the Ambulance*

In the middle of the ambulance patient cabinet, there is an ambulance stretcher platform, produced with stainless steel, located in order to facilitate movements of the stretcher. This platform is able to carry a patient whose weight is at least 250 kilograms. Also, it has 10g crash test certificate, which is compatible with 1789 standards.



## TECHNICAL AND MEDICAL EQUIPMENT IN *MERCEDES BOX TYPE AMBULANCE*

### *Main Stretcher*

Ambulance stretcher, manufactured from stainless ethyl 61(AA 6351) material, is mounted on the ambulance platform. The ambulance stretcher is produced compatible with EN1789 and EN1865 norms. There are 4 stretcher wheels, which have a 15cm or 20cm diameter, on the ambulance stretcher. It is provided to make CPR application on the main stretcher.

### *Defibrillator Device*

It is mounted the top of the main stretcher in the ambulance. It has features of EKG, SPO2. Moreover, it is at least 250 joules. A patient's condition can be traced from a monitor.

### *Ventilator Device*

It is mounted beside the main stretcher in the ambulance. It works with the ambulance oxygen system. It has 2 hours average use time provided full battery. Also, it can be used with a portable oxygen tube out of the ambulance. The device works with a built-in battery. Battery's lifetime is an average of 2 years.

### *Medical Materials*

The materials, which will be mentioned in the following sentence, located in the patient cabinet, are used for contributing the emergency intervention.

- >emergency birth set
- >emergency burn set
- >rescue vest
- >ambulance chair stretcher
- >oxygen system
- >vacuum aspirator
- >ambu set



## TECHNICAL AND MEDICAL EQUIPMENT IN *MERCEDES BOX TYPE AMBULANCE*

### *Patient Cabinet Seats*

There are 2 staff seats, which are compatible with en1789 norms, in the patient compartment. Seats look through the cruising direction while the ambulance is in motion. Seats have a safety belt with 3 points. Also, they can lie to back at most 160 degrees.

The ambulance cabinet internal surfaces are rounded in order to prevent possible accidents while the ambulance in motion..

### *Oxygen System*

There are two oxygen tubes produced 2x10 aluminum in the ambulance. These tubes are located on the left side provided that looking to the vehicle from the left back door.

There is a sequential system valve that allows the use of the oxygen system. Oxygen tubes are produced compatible with EN 7866 standards. There are two oxygen sockets in the ambulance cabinet in order to give an oxygen output. There are flowmeter, moisturizer, and oxygen suction jar on the sockets.

At AmbulanceMed, we pride ourselves on equipping our ambulances with the latest and most advanced technology. Our goal is to ensure that every ambulance is fully equipped with state-of-the-art and customized equipment, tailored to meet the specific needs of emergency medical services. From cutting-edge medical devices to user-friendly layouts, we have meticulously designed the interior to provide optimal functionality and care. With AmbulanceMed, you can trust that our technologically advanced ambulances are ready to deliver top-notch service in any situation.



**OUR  
WORKS**



# MEDICAL EQUIPMENTS

## MEDICAL EQUIPMENTS

	ORIGIN	STANDARD	QTY
Ambulance Main Stretcher	Turkey	CE / EN 1865 / EN 1789 / ISO 9001	1
Ambulance Chair Stretcher	Turkey	CE / EN 1865 / EN 1789 / ISO 9001	1
Ambulance Scoop Stretcher	Turkey	CE / EN 1865 / EN 1789 / ISO 9001	1
Ambulance Spine board Stretcher	Turkey	CE / EN 1865 / EN 1789 / ISO 9001	1
Ambulance Air Split Set	German/Turkey	CE / EN 1865 / EN 1789 / ISO 9001	1
Ambulance Cervical Coller	German	CE / EN 1865 / EN 1789 / ISO 9001	1
Ambulance Birth Set	German	CE / EN 1865 / EN 1789 / ISO 9001	1
Ambulance Burn Set	German	CE / EN 1865 / EN 1789 / ISO 9001	1
Ambulance Portable Suction Set	German/Turkey	CE / EN 1865 / EN 1789 / ISO 9001	1
Ambulance Defibrillator AED	German	CE / EN 1865 / EN 1789 / ISO 9001	1
Ambulance Transportation Ventilator	German	CE / EN 1865 / EN 1789 / ISO 9001	1

Ambulance Reanimation Set	German/Turkey	CE / EN 1865 / EN 1789 / ISO 9001	1
Ambulance Fixed Spyhg	German	CE / EN 1865 / EN 1789 / ISO 9001	1
Ambulance Portable Spyhg	German	CE / EN 1865 / EN 1789 / ISO 9001	1
Ambulance Stethoscope	German	CE / EN 1865 / EN 1789 / ISO 9001	1
Ambulance Corpse Bag	Turkey	CE / EN 1865 / EN 1789 / ISO 9001	1
Ambulance Basic Medical Equipment Bag	German/Turkey	CE / EN 1865 / EN 1789 / ISO 9001	1
Ambulance Oxygen and Vacuum Systems	Turkey	CE / EN 1865 / EN 1789 / ISO 9001	1
Ambulance Oxygen Cylinder 10Ltx2	Turkey	CE / EN 1865 / EN 1789 / ISO 9001	1
Ambulance Oxygen Outlet	Turkey	CE / EN 1865 / EN 1789 / ISO 9001	1
Ambulance Oxygen Regulator & Flowmeter	Turkey	CE / EN 1865 / EN 1789 / ISO 9001	1



**Ambulancemed**



## TECHNICAL EQUIPMENTS

	ORIGIN	STANDARD	QTY
Front beacon lamp with LED	Turkey	ECR-65	1
Back beacon lamp with LED + projector	Turkey	ECR-65	1
Siren Announce Device (5 stage)	Turkey	ECR-65	1
Side warning lights with LED 12 volt	Turkey	ECR-65	6
Patient's Cabin Lighting (LED)	Turkey	CE	2
Patient's Cabin Lighting (Spot LED)	Holland	CE	2
Air Condition	Turkey	CE / ISO 9001	1
Electrical System	Turkey	CE / ISO 9001	1
Digital Control Panel	Turkey	CE / ISO 9001	1
Rectifier	Turkey	CE / ISO 9001	1
Rectifier Cable	Turkey	CE / ISO 9001	1
Socket	Turkey	CE / ISO 9001	1
Inverter 1000W	Turkey	CE / ISO 9001	1

## TECHNICAL EQUIPMENTS

Outlet 220V	Turkey	CE / ISO 9001	1
Fuse Circuit Breaker	Turkey	CE / ISO 9001	1
Led Lighting	Turkey	CE / ISO 9001	1
Stretcher Spotlight	Turkey	CE / ISO 9001	1
Electronic Siren and Light Bar	Turkey	CE / ISO 9001	1
Back Top Lightbar	Turkey	CE / ISO 9001	1
Side Warnings Lamps	Turkey	CE / ISO 9001	1

The technical equipment in our ambulances is designed to meet the highest standards of quality and functionality. Please note that these equipment are subject to regular updates and advancements in line with evolving medical technologies. We are committed to ensuring that our ambulances are equipped with the most up-to-date and state-of-the-art technology to provide the best possible care.



**Ambulancemed**



TECHNICAL DESIGNS  
SPECIFICATION

**Ambulancem**

# CAD DESIGN FOR THE MANUFACTURING PROCESS

## Main External Body:

The external body of this structure is meticulously crafted using Polyurethane panels for both the body and doors. Polyurethane is chosen for its exceptional mechanical properties, boasting high strength, lightweight characteristics, and excellent insulation, effectively preventing the transfer of heat, cold, and noise. To reinforce durability and structural integrity, aluminum 5254 is utilized for the construction of corners and edges. This combination of materials ensures a robust and thermally efficient exterior body.

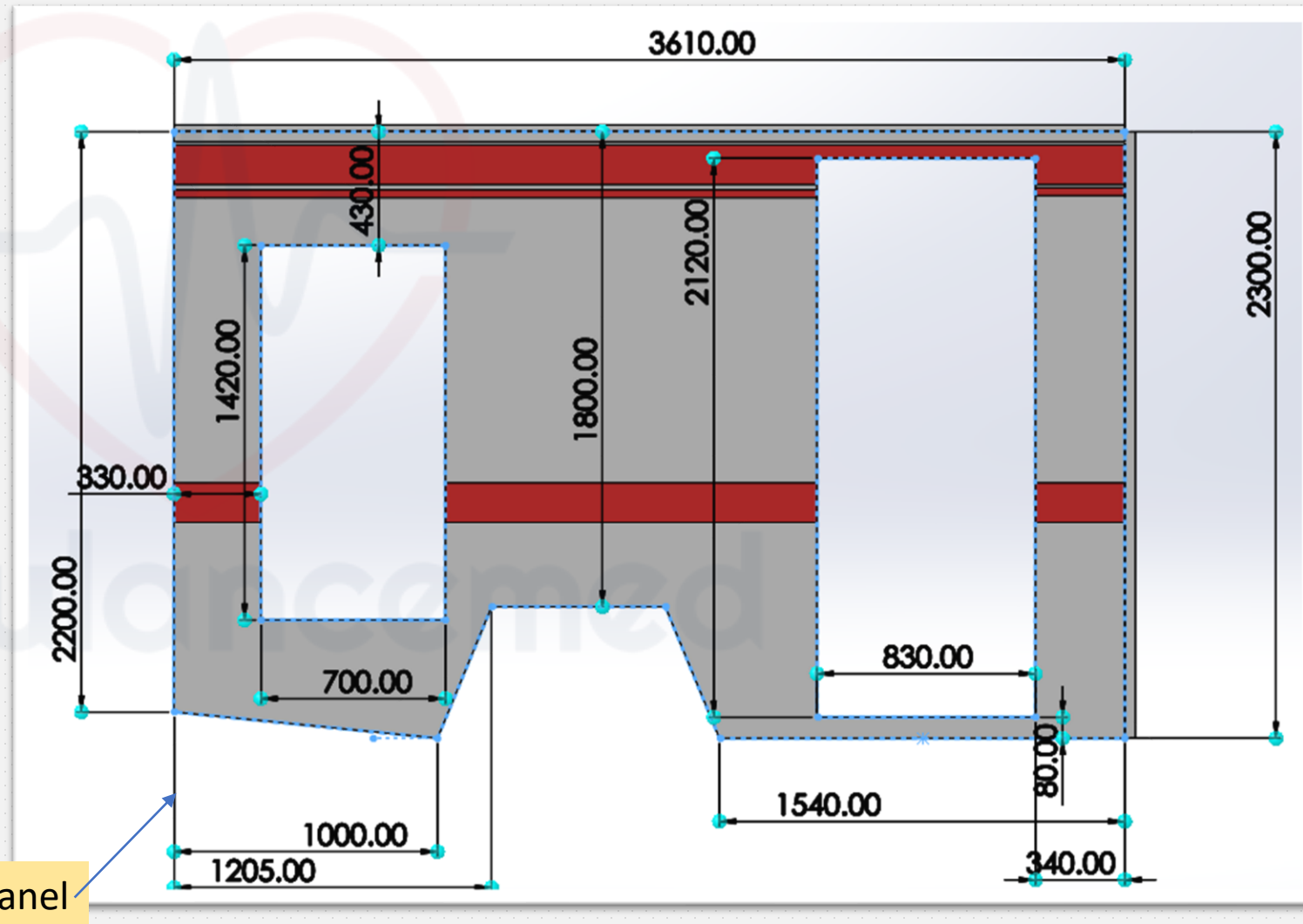

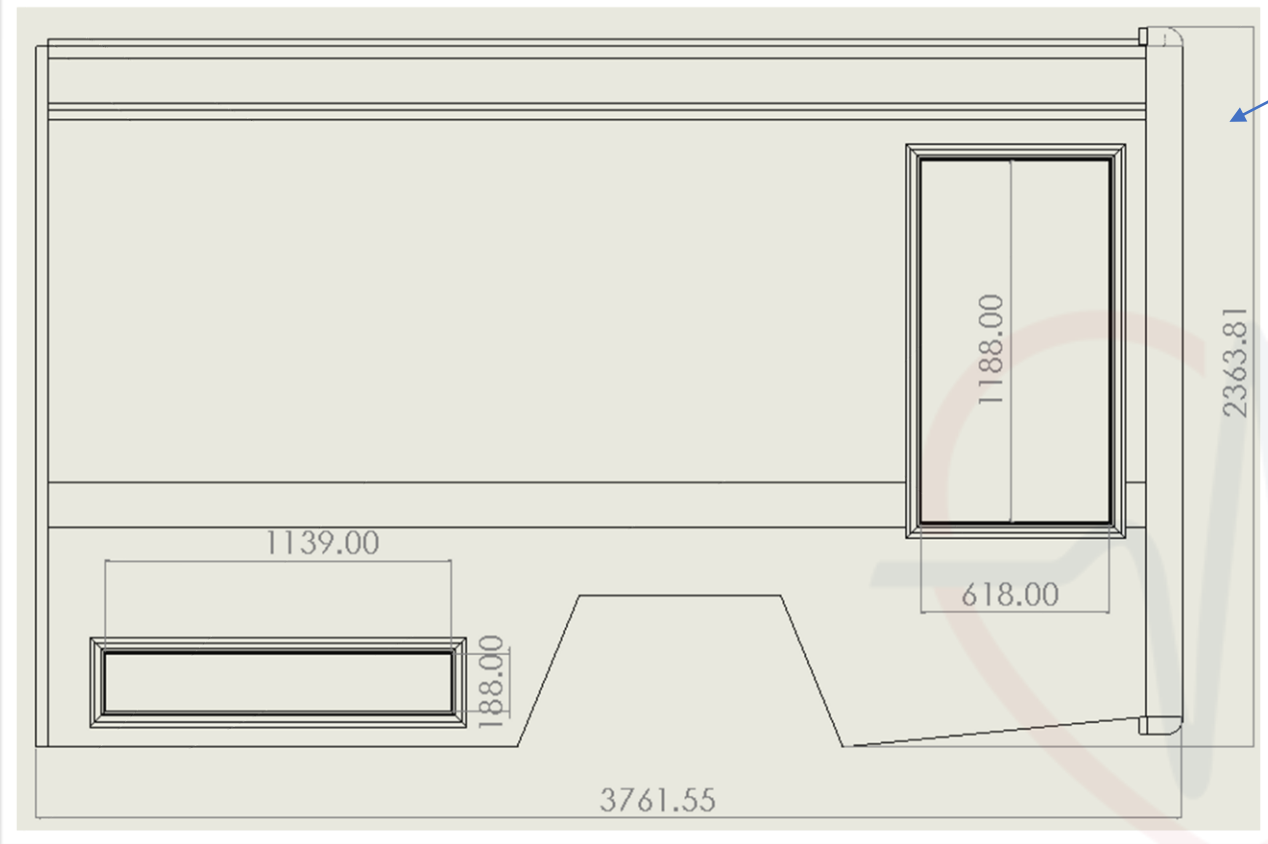

Left panel

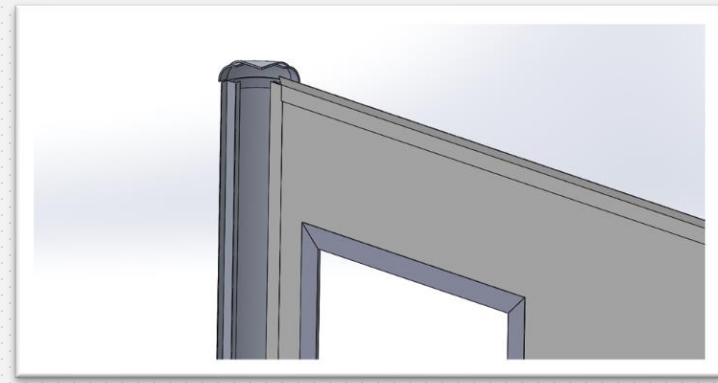

Chair Stretcher's door Aluminum profile edges well tight assembled

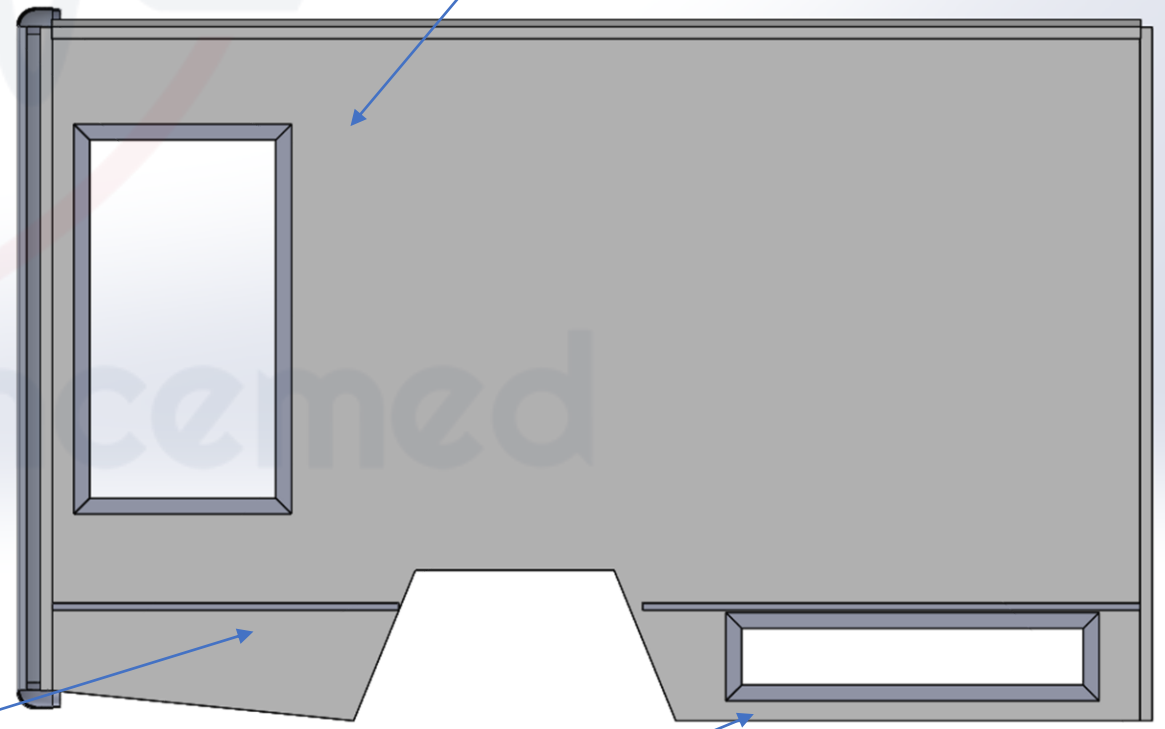

Angle trim 40\*25mm well fastened on the panel and on the box platform structure

Luggage's door Aluminum edges



Figure 2

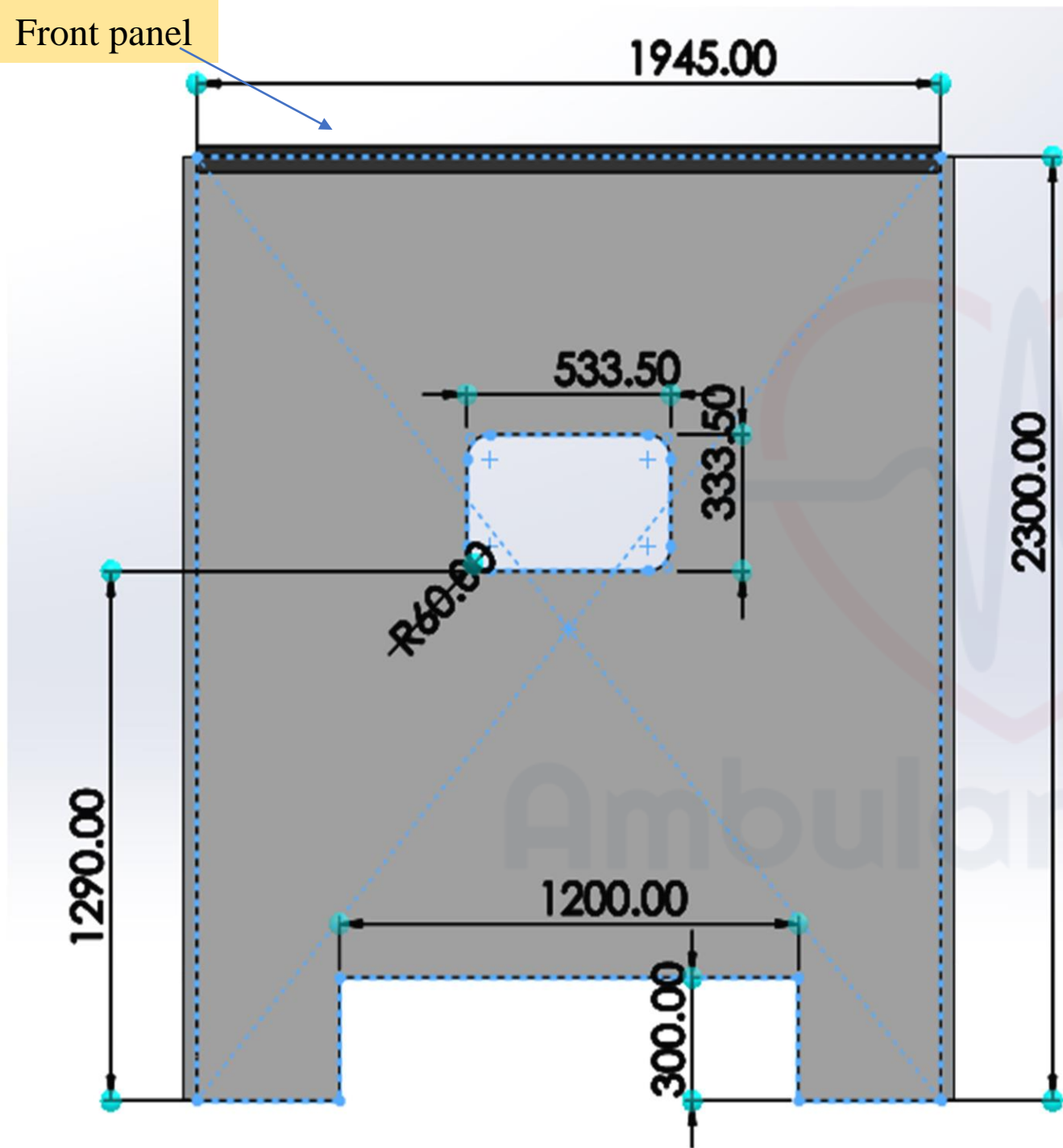

Driver's rear window plexiglass slides

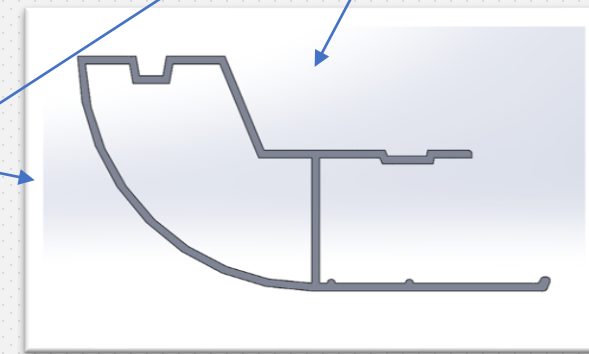
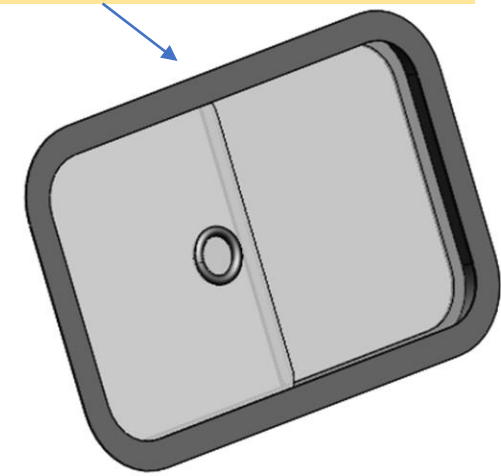

The box's edge profile, crafted from sleek and durable aluminum, which will be assembled to the panel corners with bolts and silicon.

Figure 3

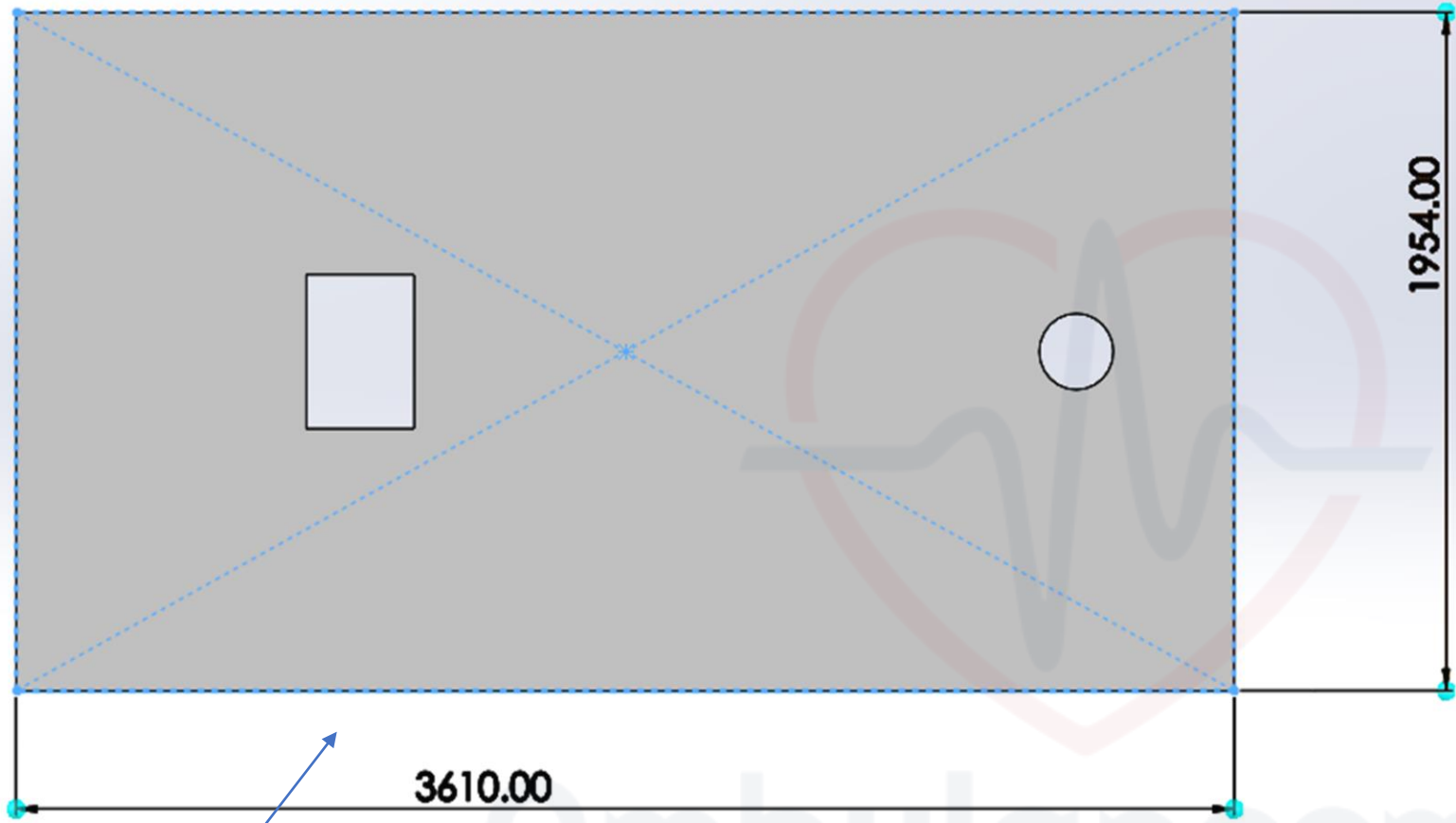

Top panel

**Roof Structure:** The framework consists of ST-37 steel profiles meticulously welded and securely bolted to the roof's polyurethane panel. This design facilitates the seamless routing of electrical components, including cables, for connection to vital systems such as air conditioning, fans, and lighting.

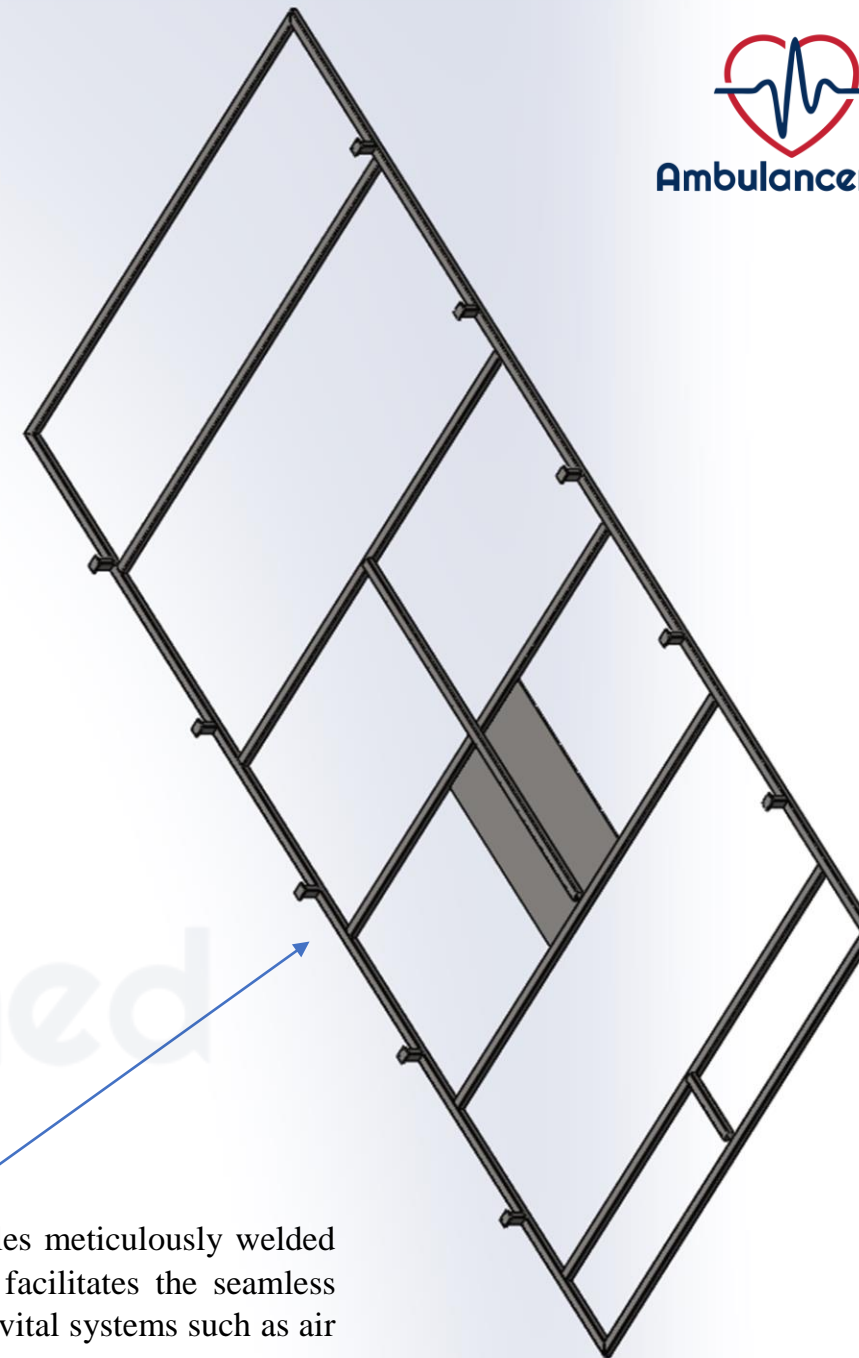
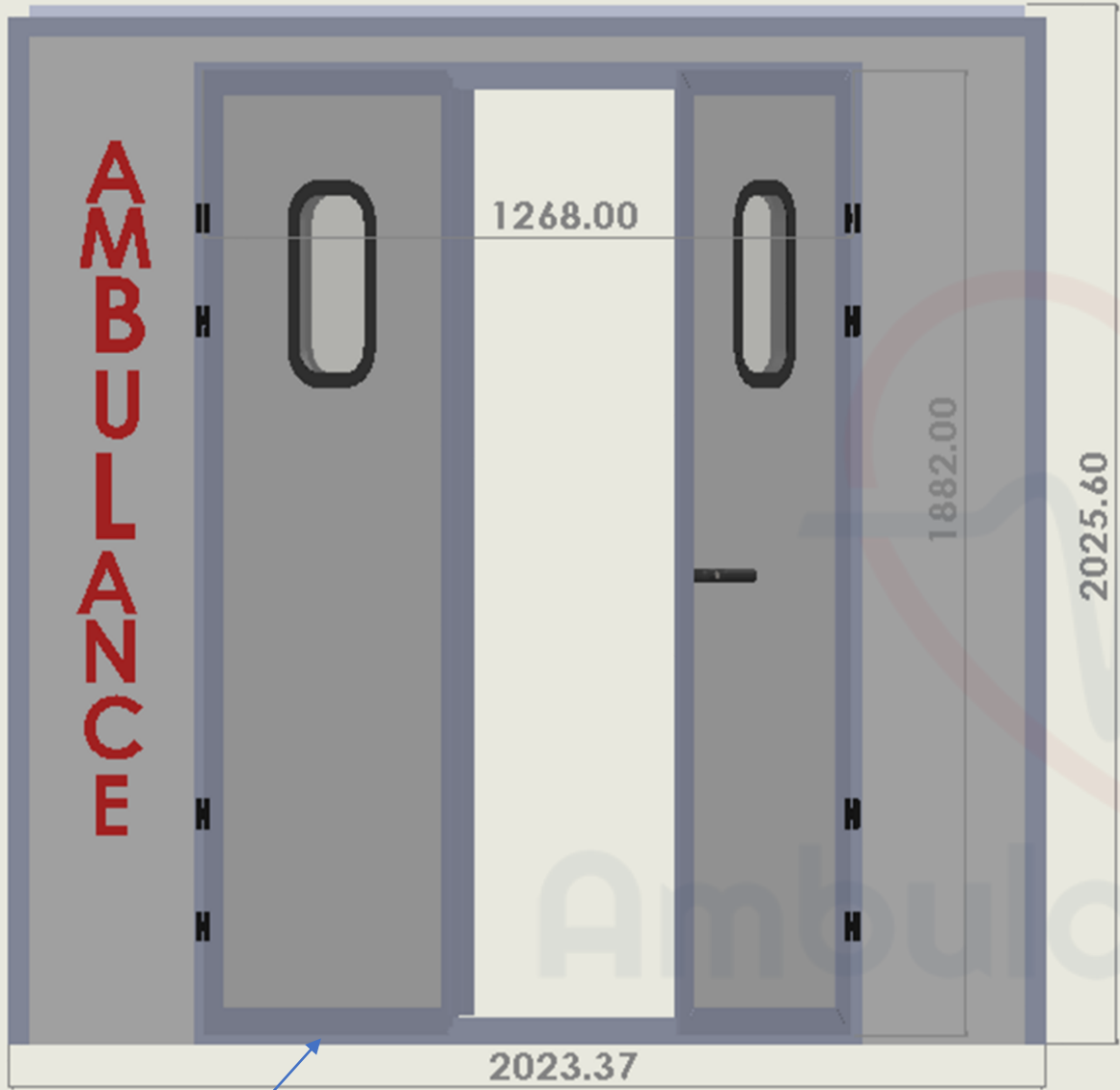
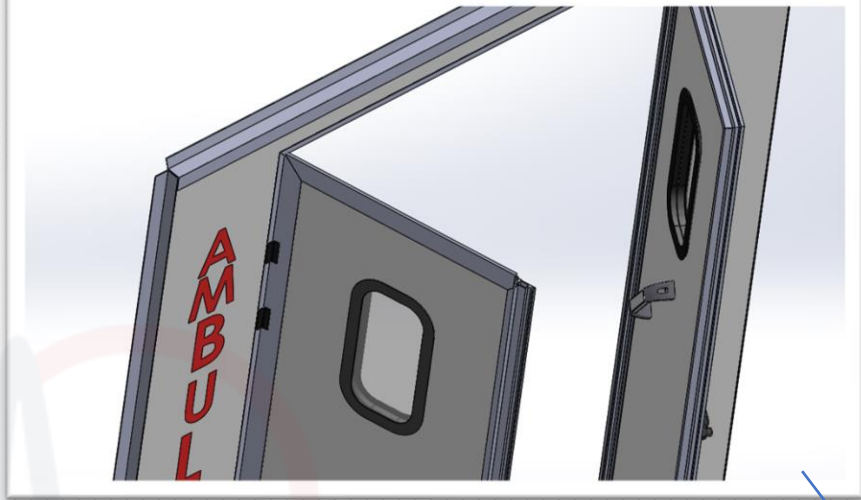

Figure 4



Rear panel



Rear door Aluminum profile edges well tight assembled on the door's panel

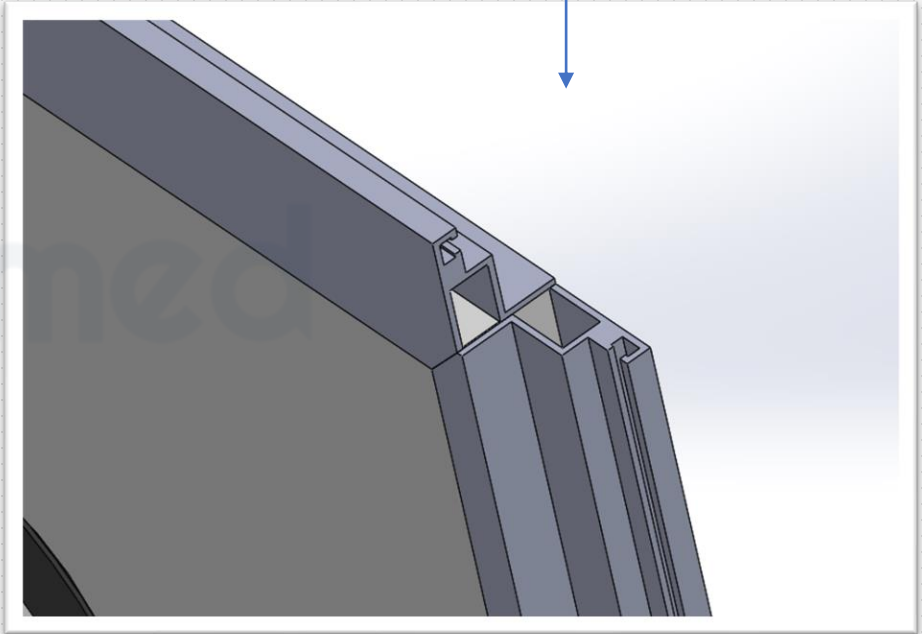
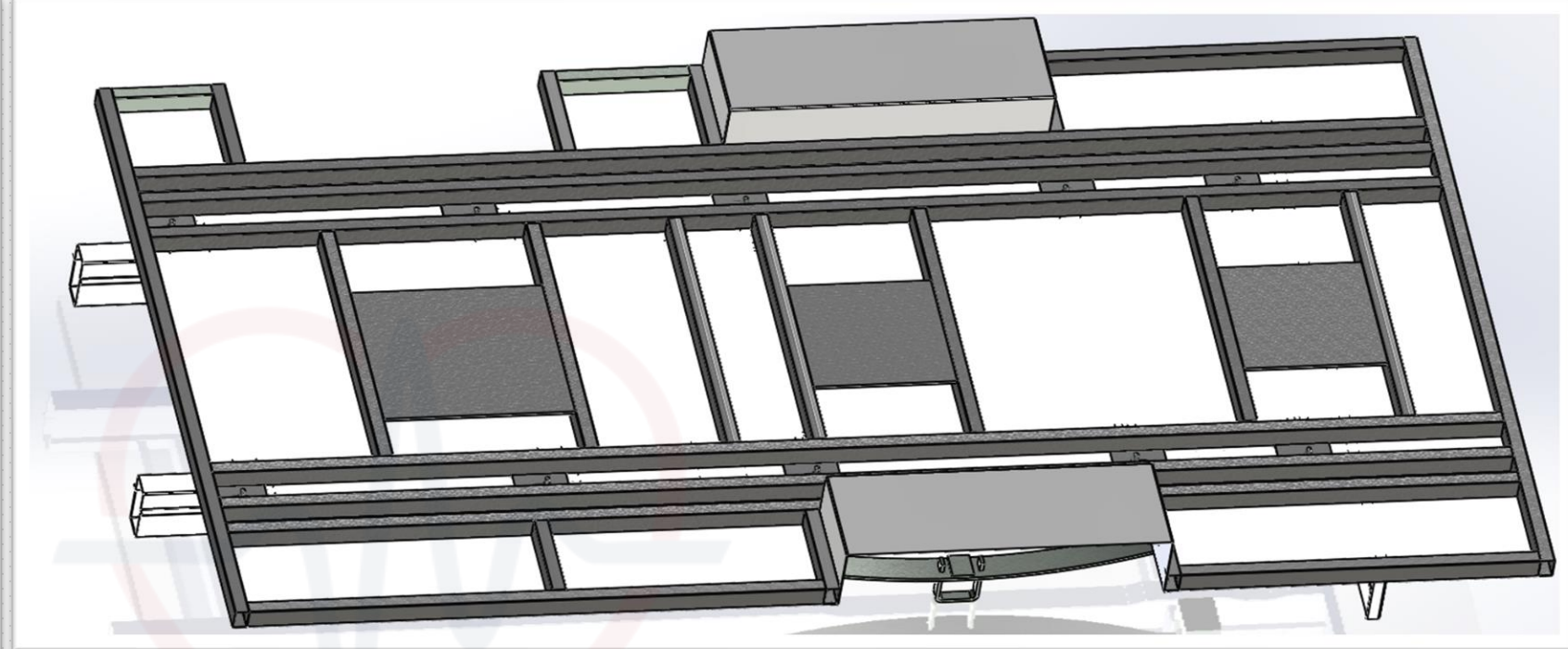
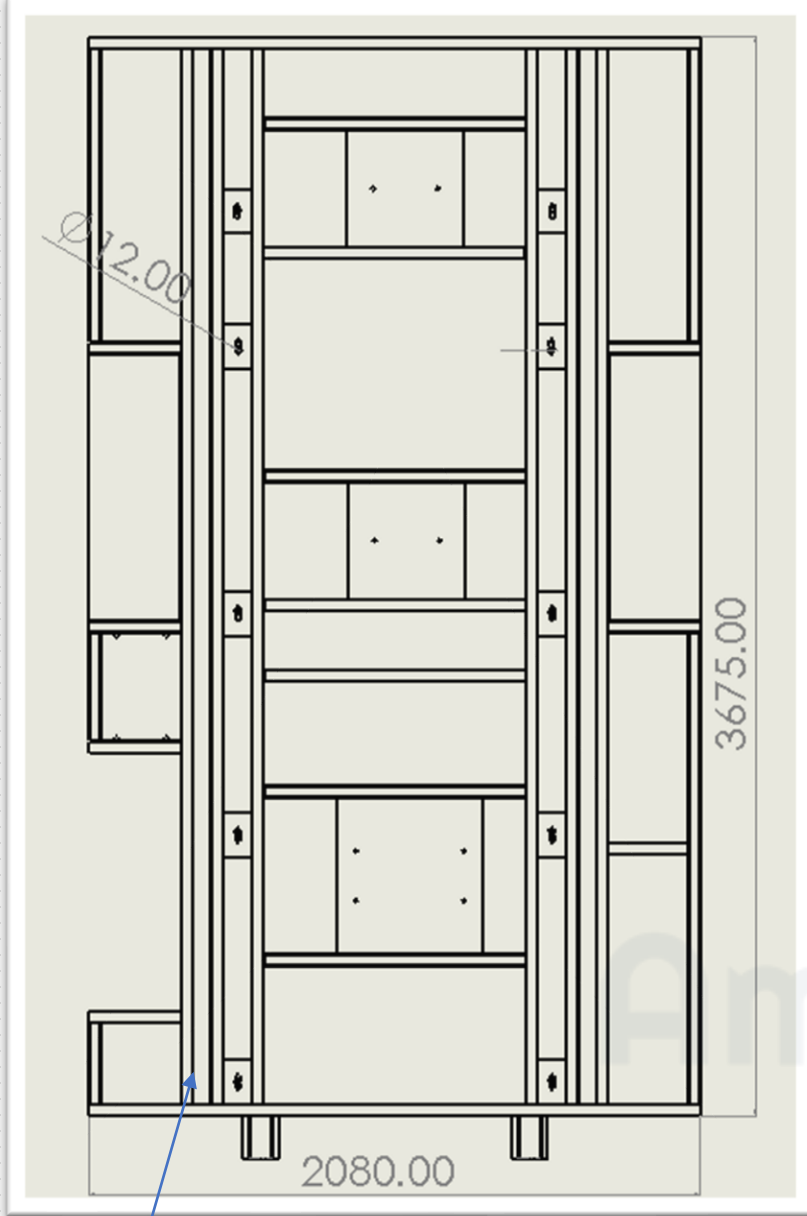

Figure 5



### Chassis Structure:

The framework is constructed using ST-37 steel profiles that are expertly welded and securely fastened to the car's chassis, ensuring that any potential disassembly and reassembly can be achieved with ease and without complications. Within the framework, stone-wool insulation will be integrated to effectively insulate against external heat, cold, and noise transmission from the ground, thereby maintaining a consistent and comfortable interior temperature.

Flanges welded upon the platform structure and will be fastened on the car's chassis with 12mm grade 9.8 bolts(5480kg load carry capacity per bolt) and nuts





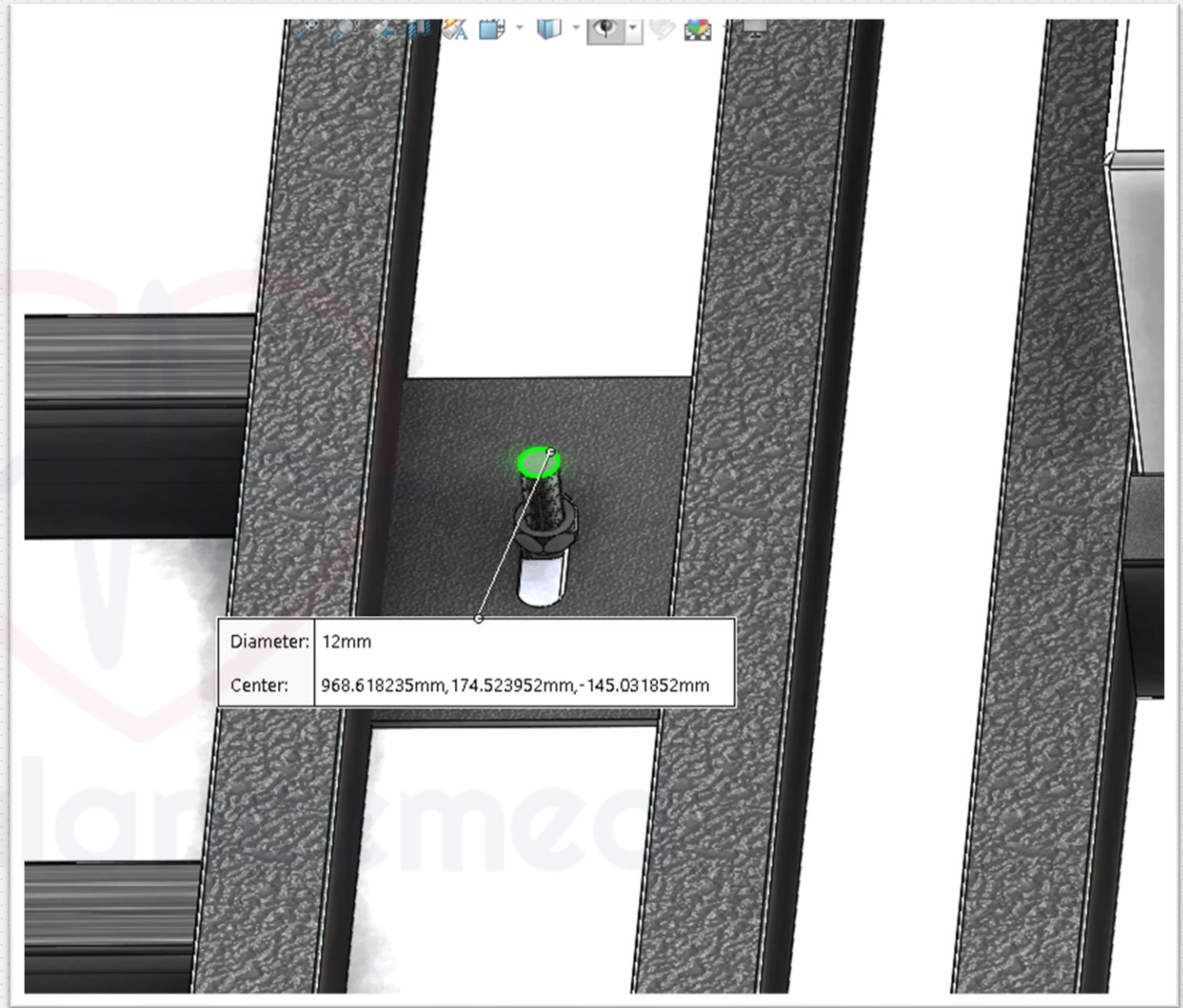
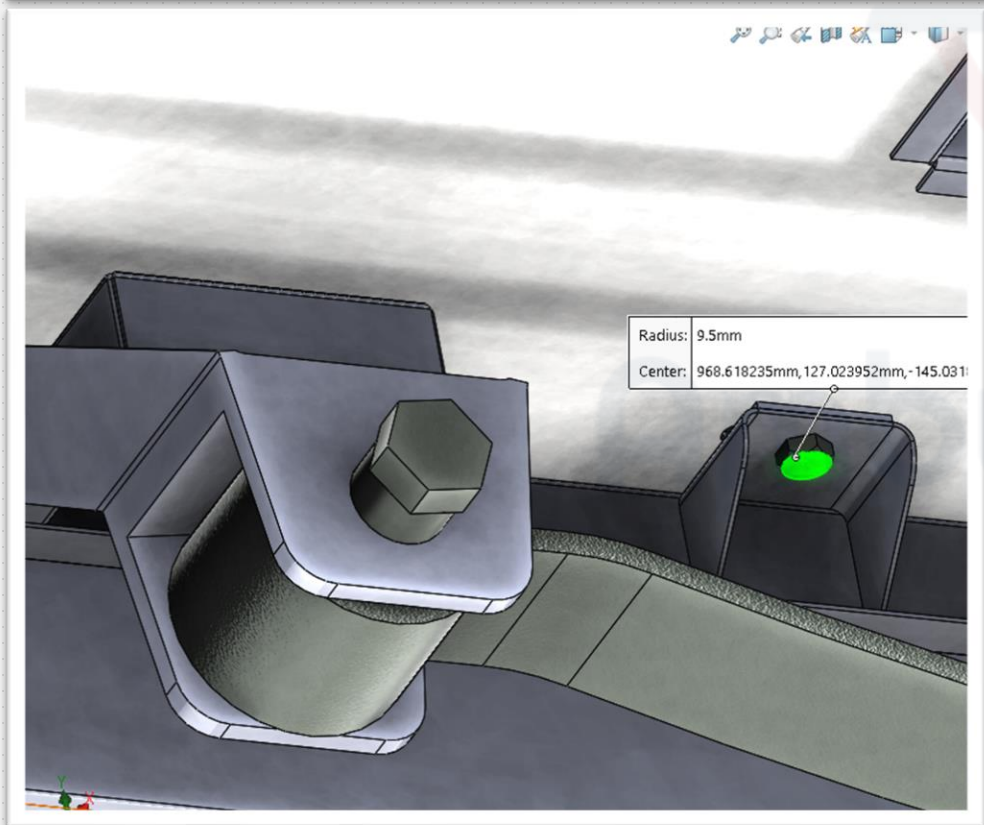
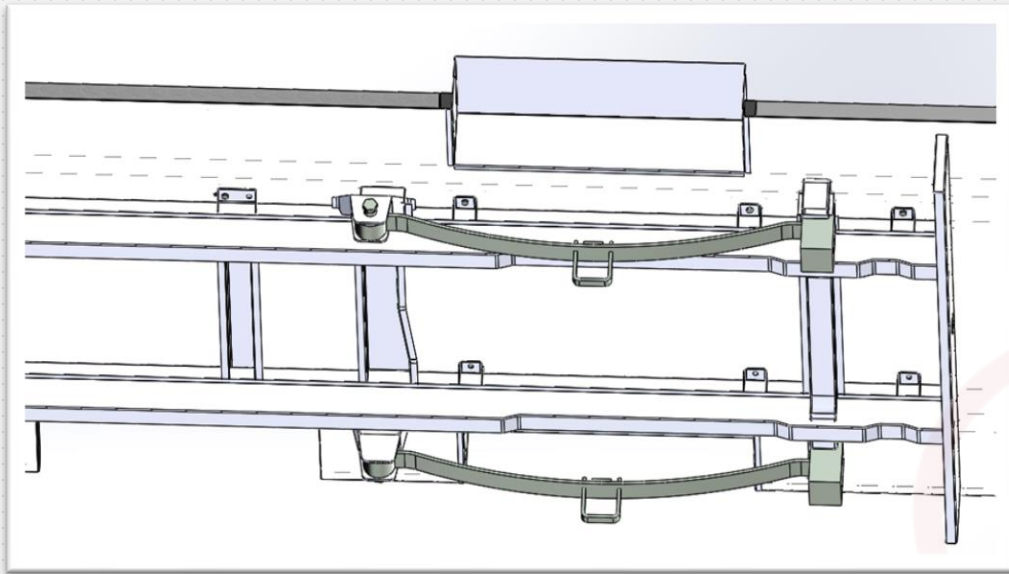

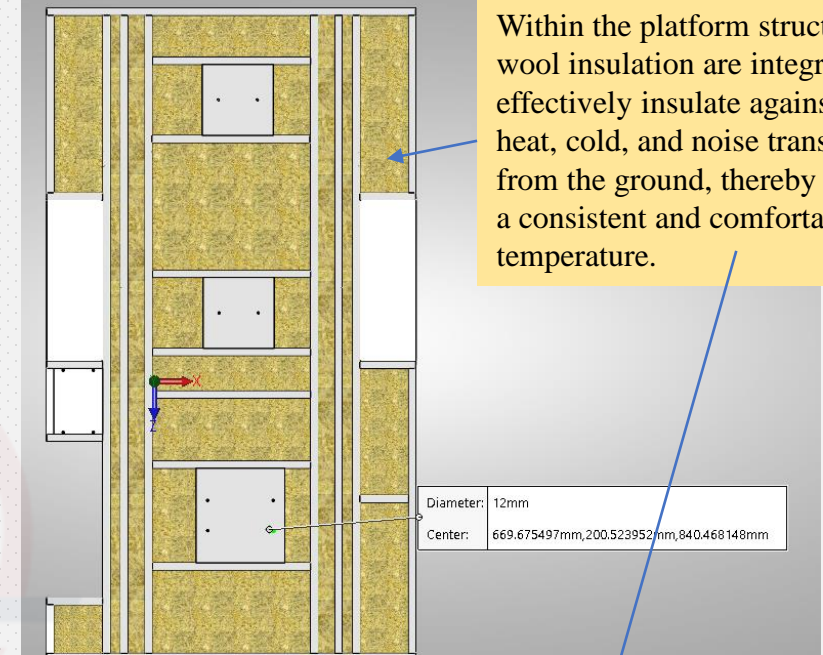
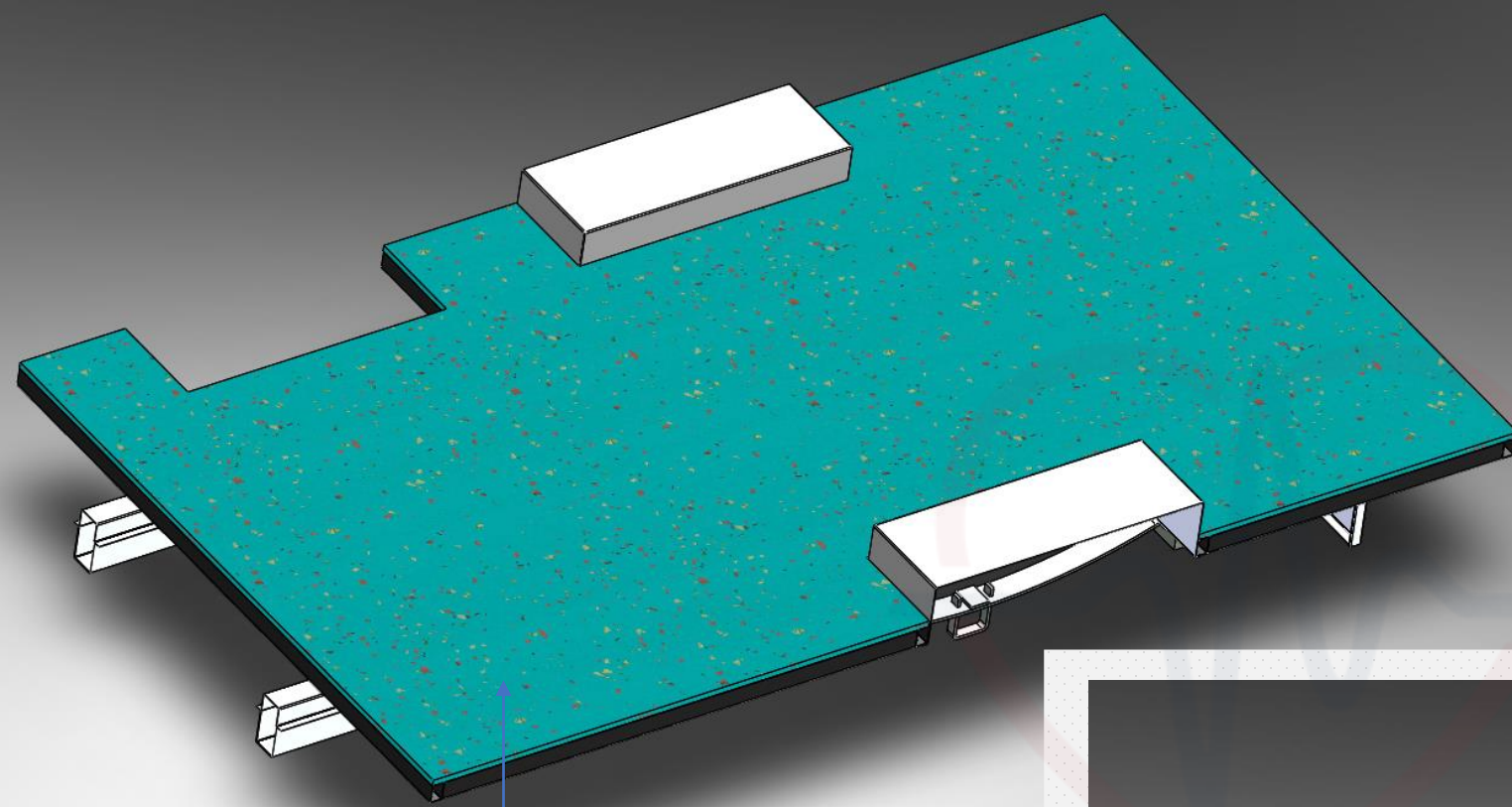

### Floor:

The flooring will be coated with epoxy, a durable, antibacterial material that offers a smooth, easily cleanable surface with zero humidity retention. Epoxy outperforms conventional flooring systems in terms of longevity, as it is highly resistant to cracking and chipping. This superior resilience ensures that accidental tool drops or impacts will not cause damage to the floor.

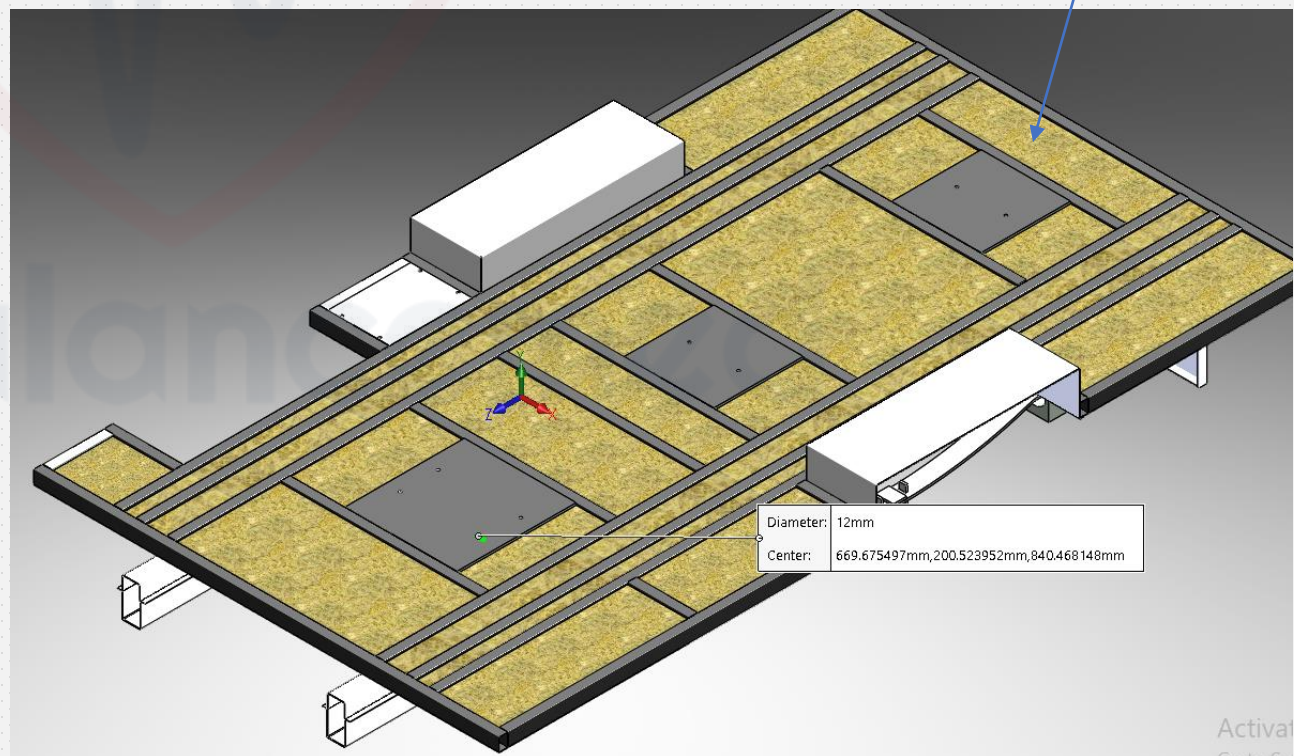

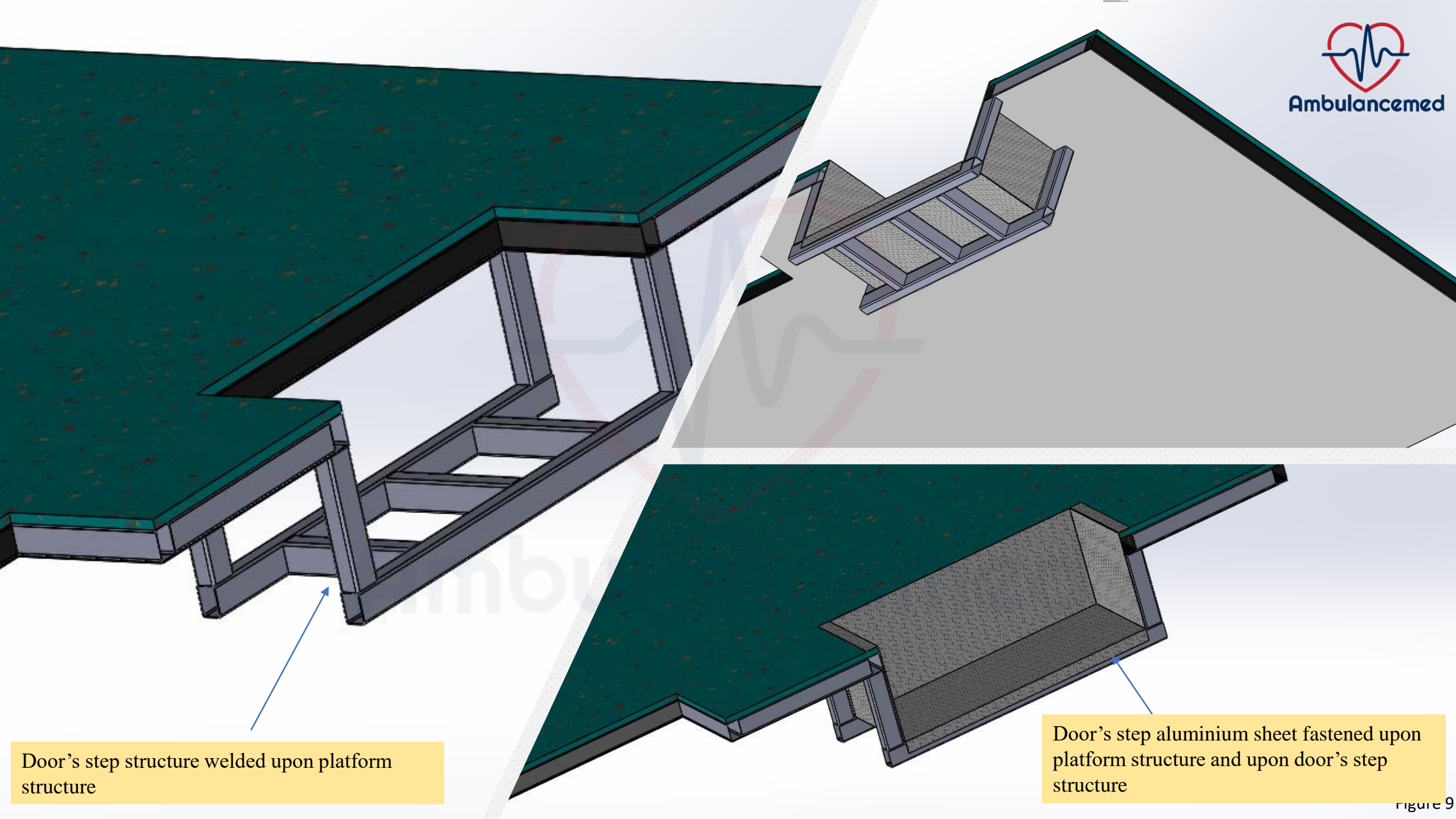

Door's step structure welded upon platform structure

Door's step aluminium sheet fastened upon platform structure and upon door's step structure

## Cabinets & Drawers:

The cabinets and drawers are constructed from Vekaplan material, a freefoam variant known for its exceptional lightweight properties and high strength. This deliberate material selection was made with the primary objective of minimizing the weight of the storage unit to ensure that it exerts minimal influence on the vehicle's acceleration. Additionally, plastic glass sheets have been incorporated into the design to enhance the overall aesthetics and functionality of the cabinetry.

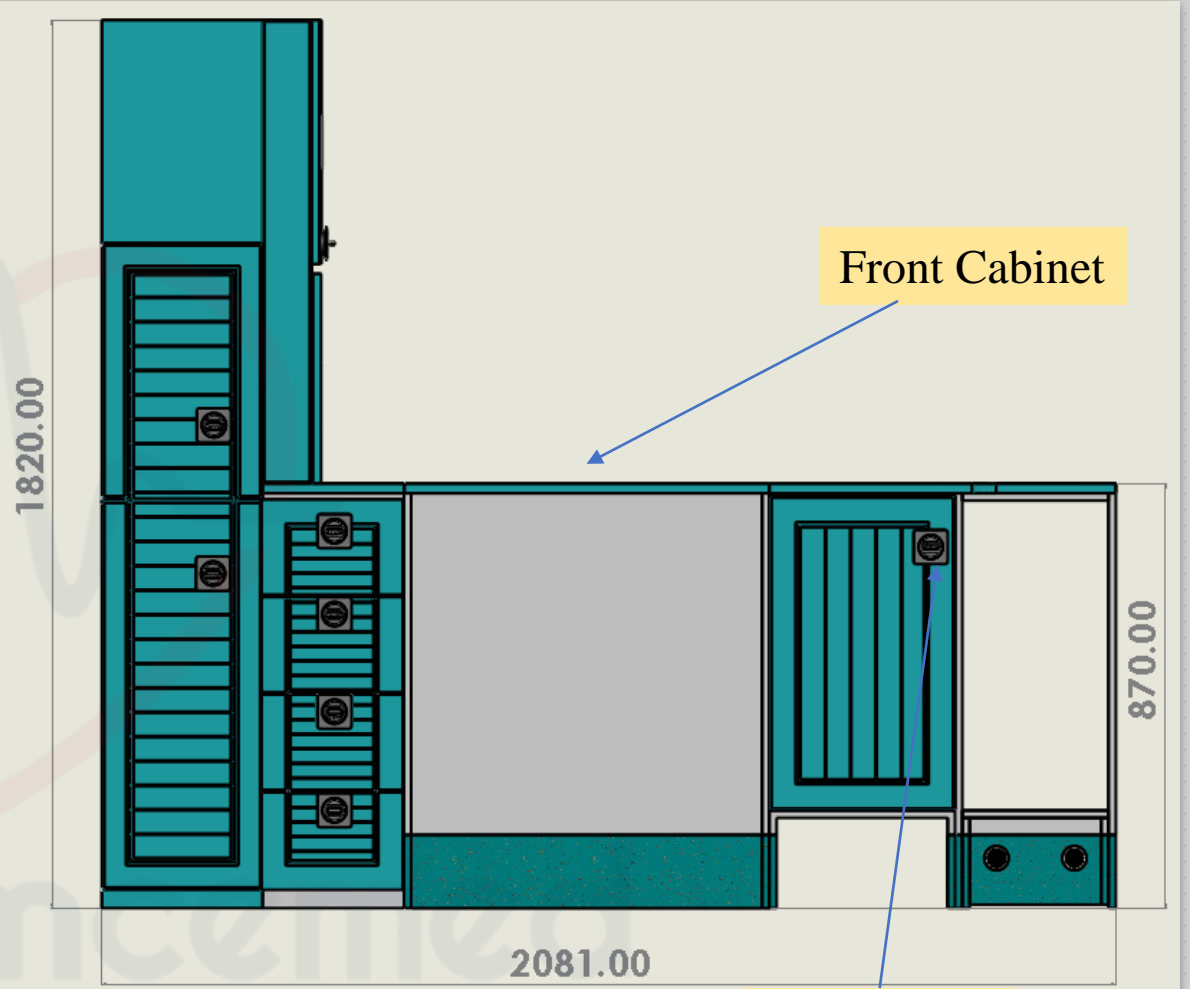
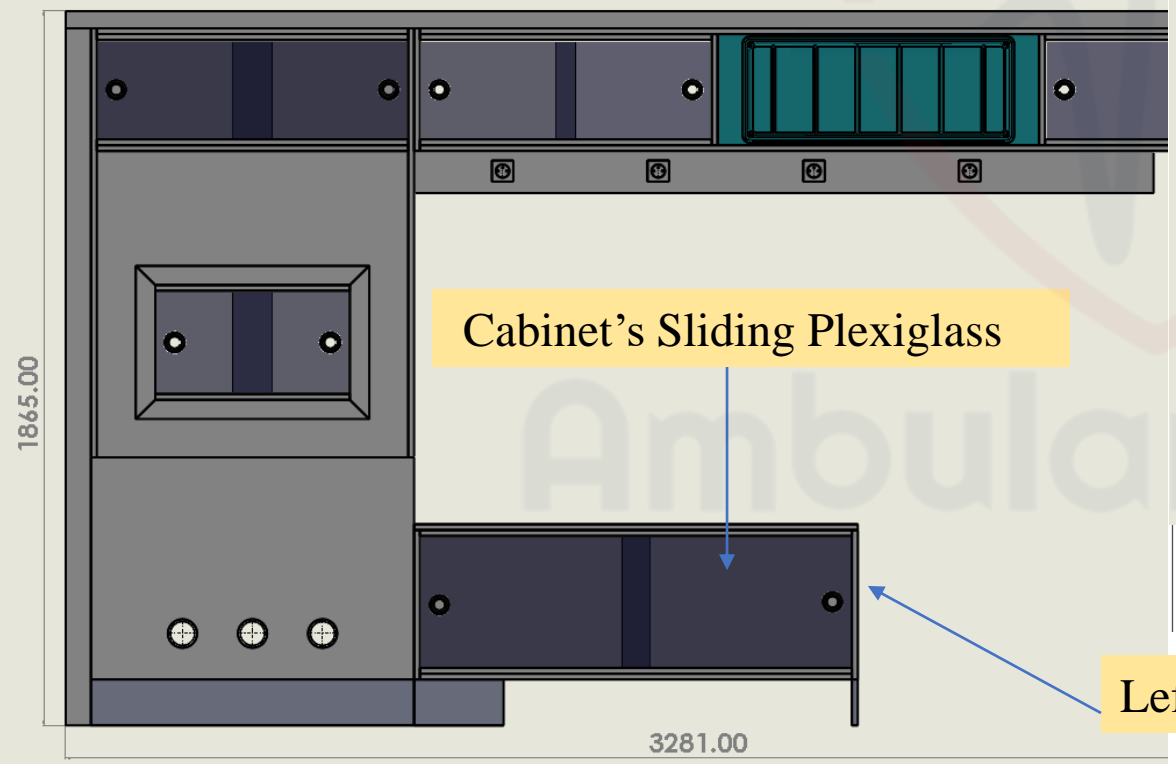
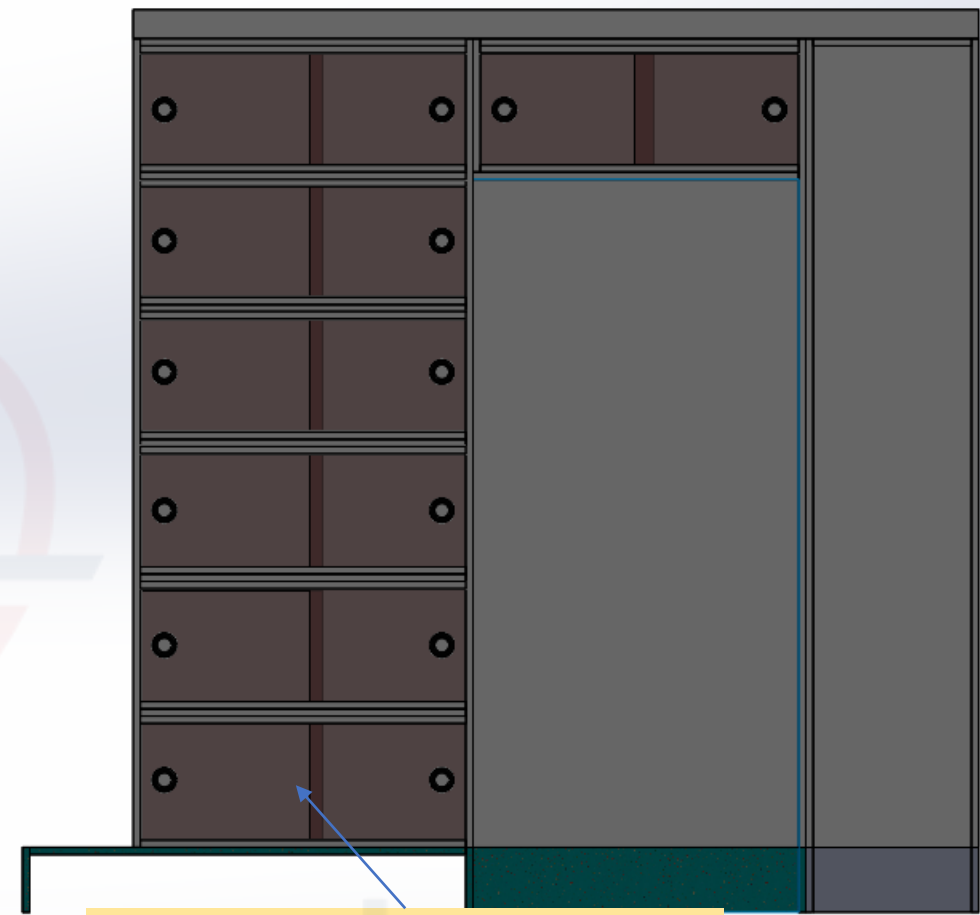
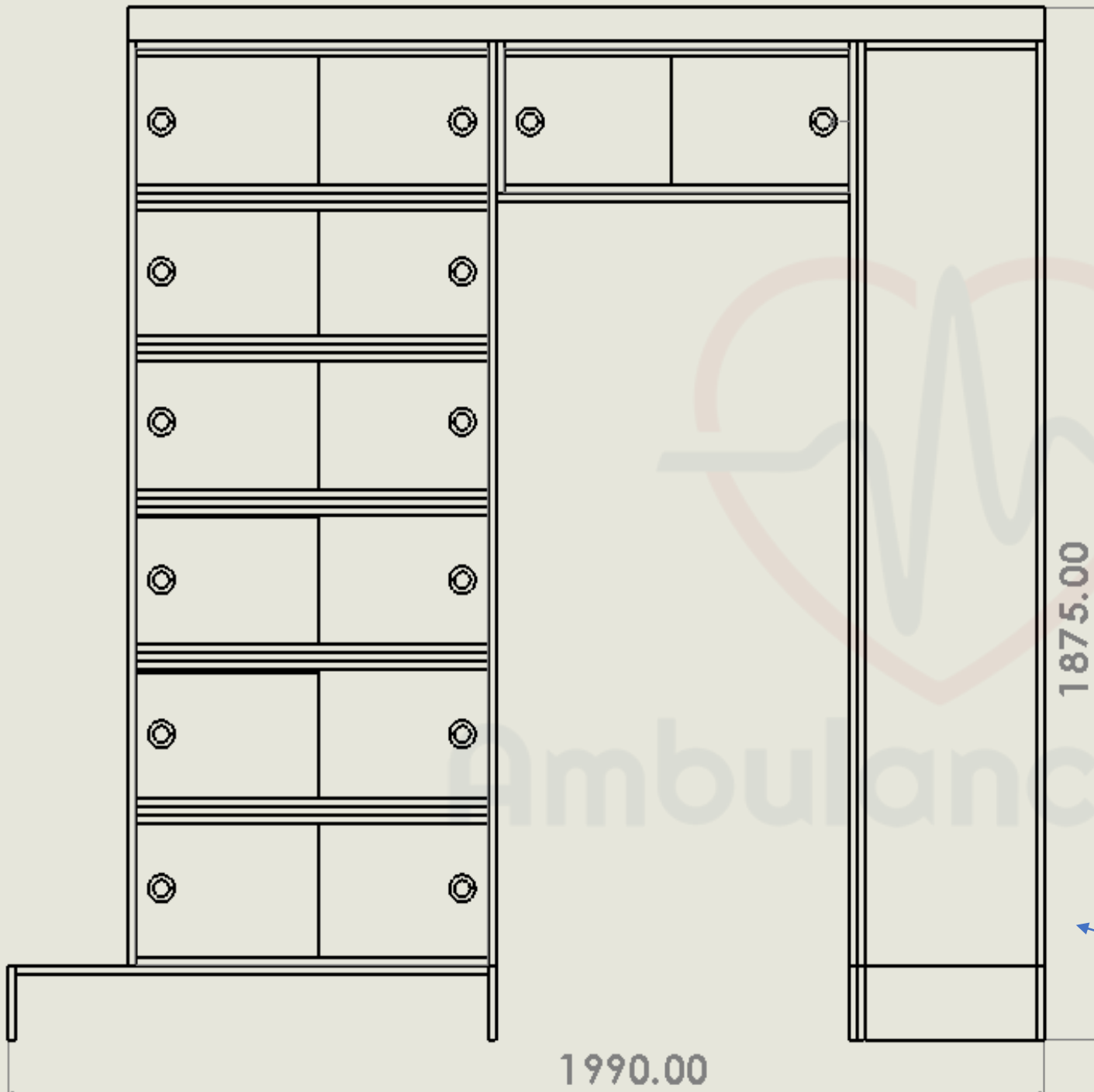

Figure 10



Cabinet's Sliding Plexiglass

Right Cabinet

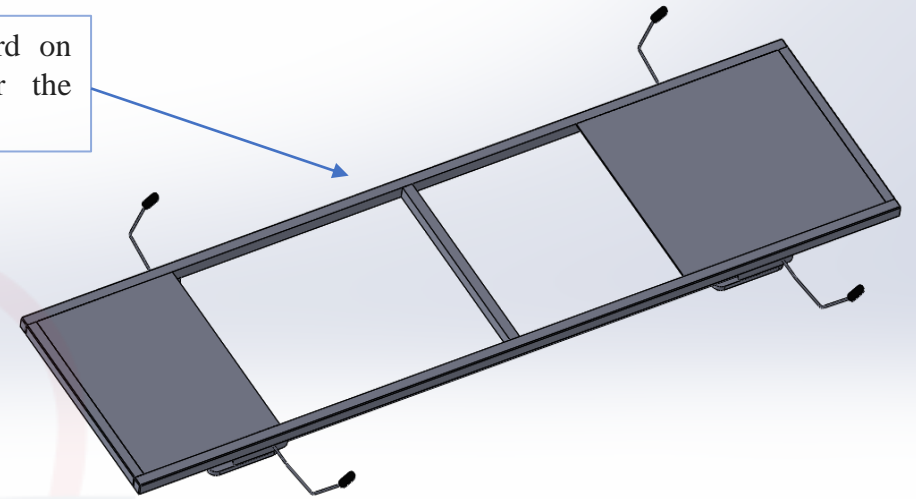
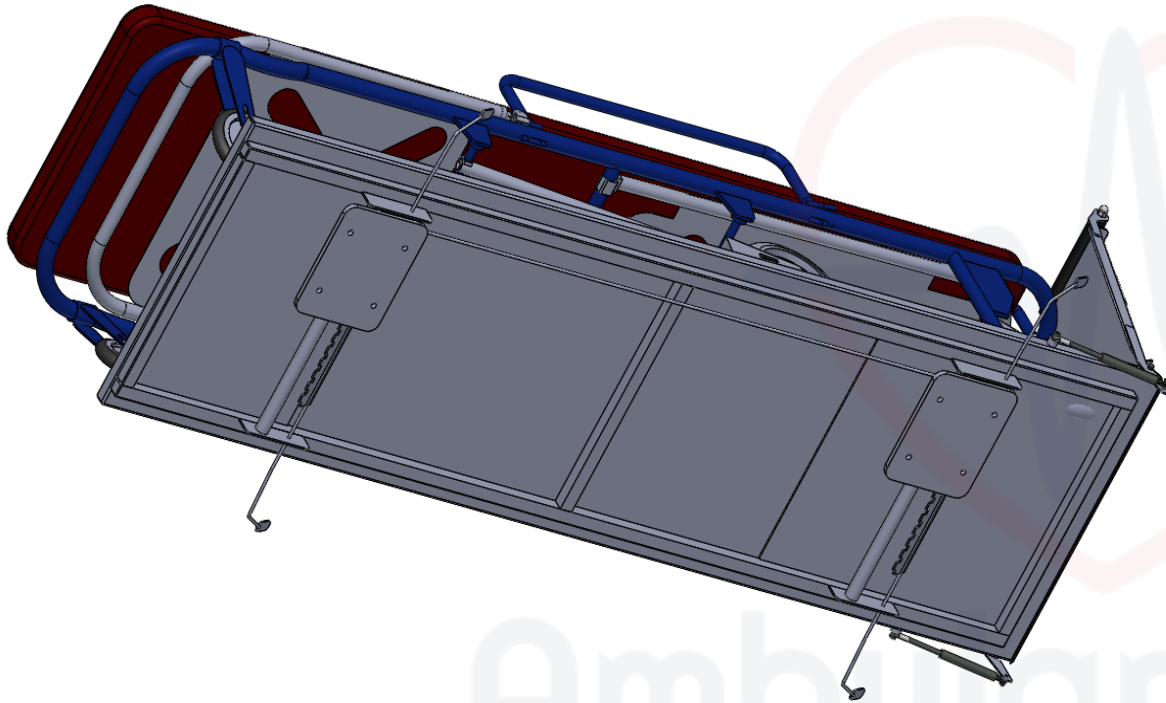

Figure 11



Ambulancemed

The stretcher base can slide backward on guide rail which is convenient for the stretcher loading& unloading.



This stretcher base is suitable for ambulance car with higher chassis, suitable for cars with chassis below 1.2m. Designed for stretchers loading and unloading conveniently.

This stretcher base is made of stainless-steel alloy materials and can load 250kg.

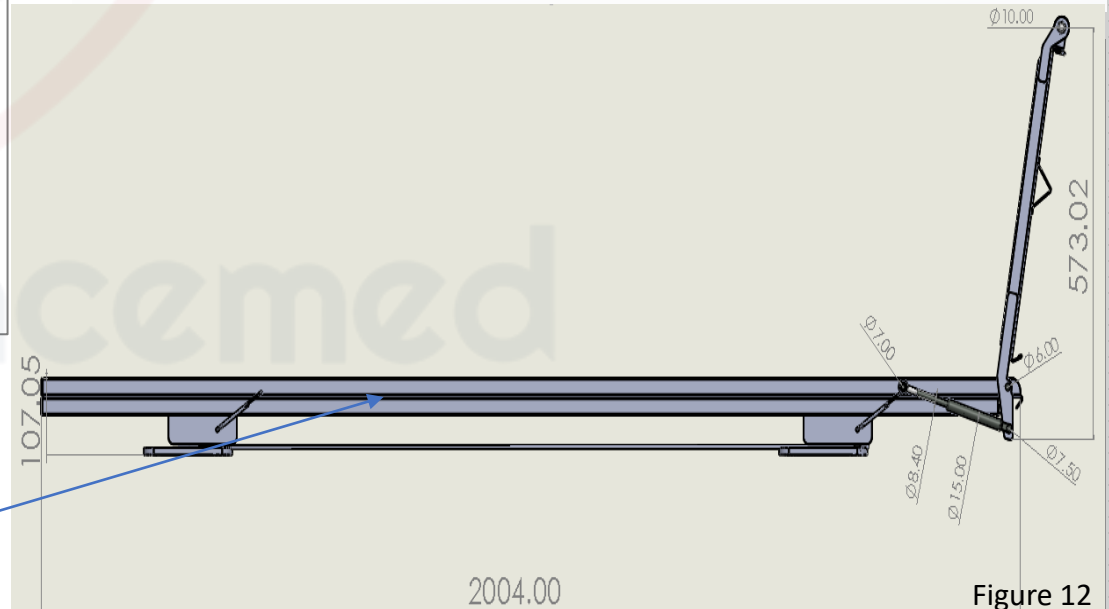
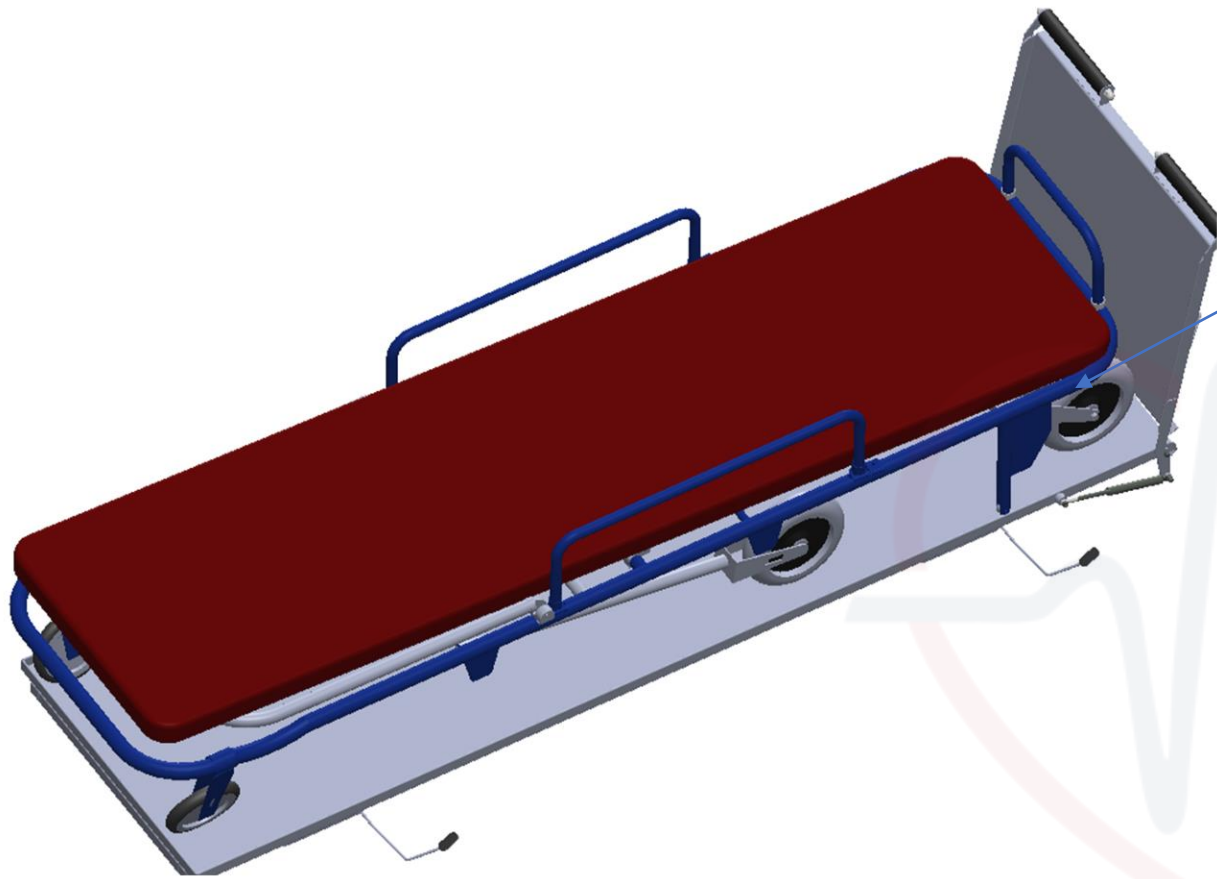
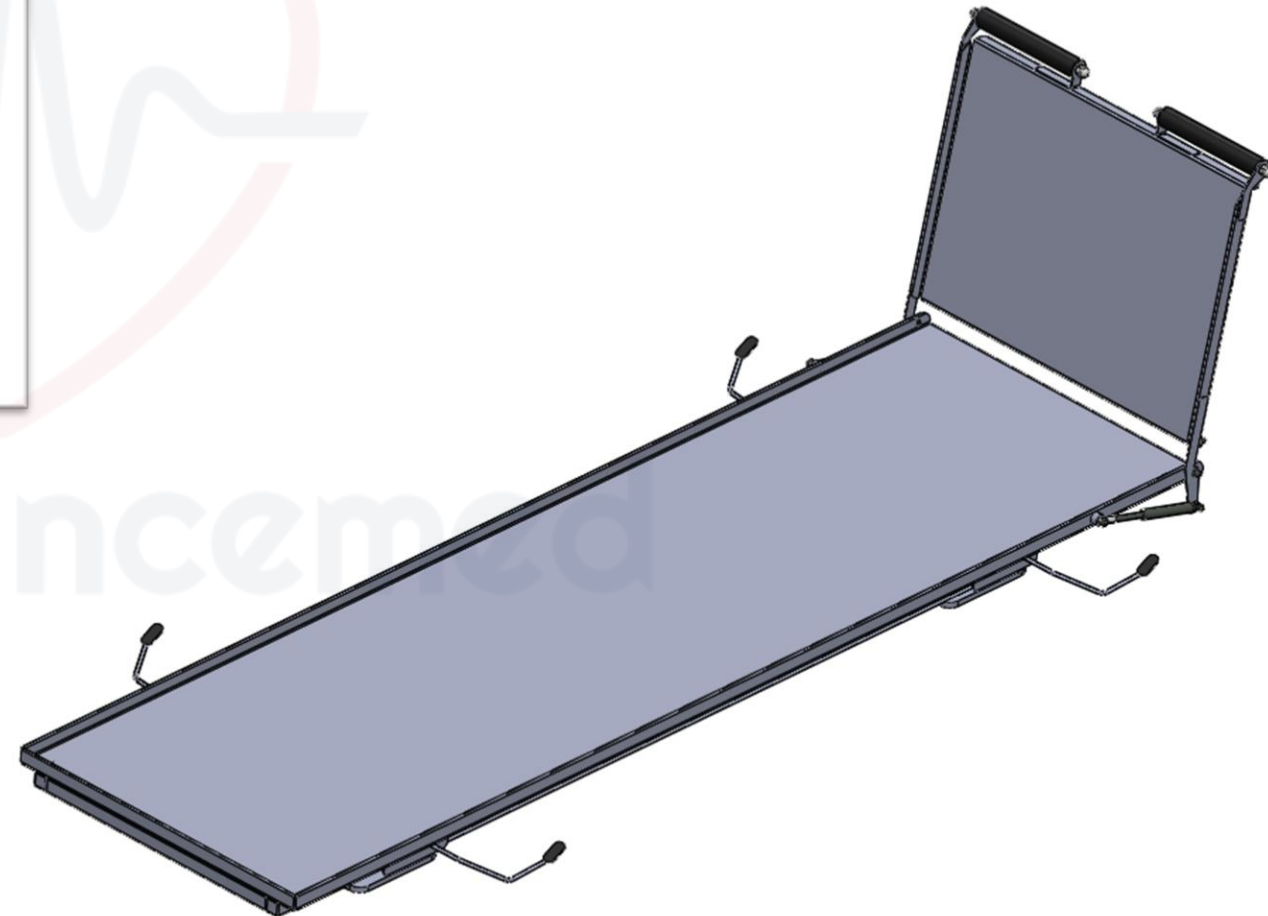

Figure 12



The Main Stretcher has the capability of carrying 250 kilograms patient in maximum. The main stretcher of the ambulance was produced from tempered aluminum pipes. With a special alloy and a changeable injection molding. The backrest part is arranged with a hydraulic system with various stages. The stretcher can be loaded and unloaded by one person easily from the ambulance.



2000.00

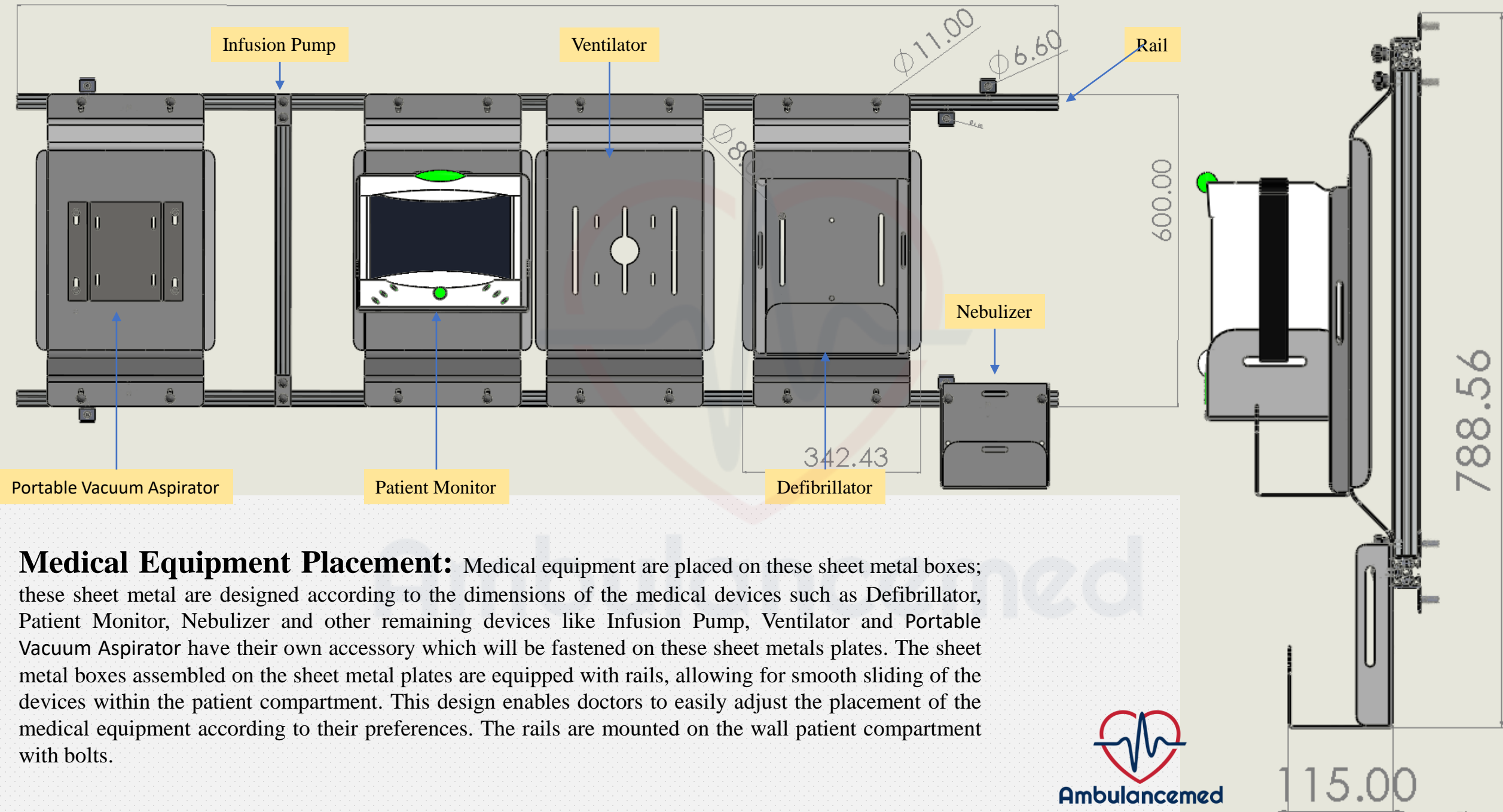

**Medical Equipment Placement:** Medical equipment are placed on these sheet metal boxes; these sheet metal are designed according to the dimensions of the medical devices such as Defibrillator, Patient Monitor, Nebulizer and other remaining devices like Infusion Pump, Ventilator and Portable Vacuum Aspirator have their own accessory which will be fastened on these sheet metals plates. The sheet metal boxes assembled on the sheet metal plates are equipped with rails, allowing for smooth sliding of the devices within the patient compartment. This design enables doctors to easily adjust the placement of the medical equipment according to their preferences. The rails are mounted on the wall patient compartment with bolts.

Figure 14



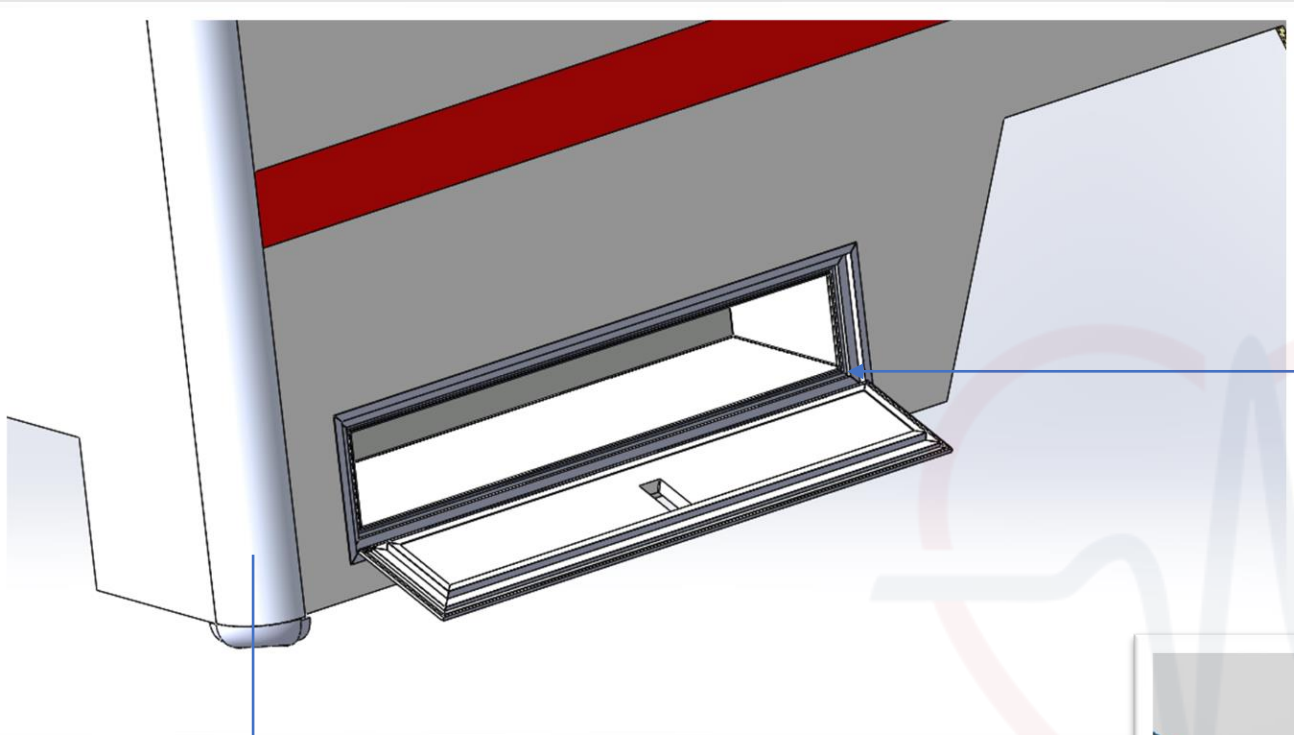

Luggage for some spare equipment storage made of aluminum sheet

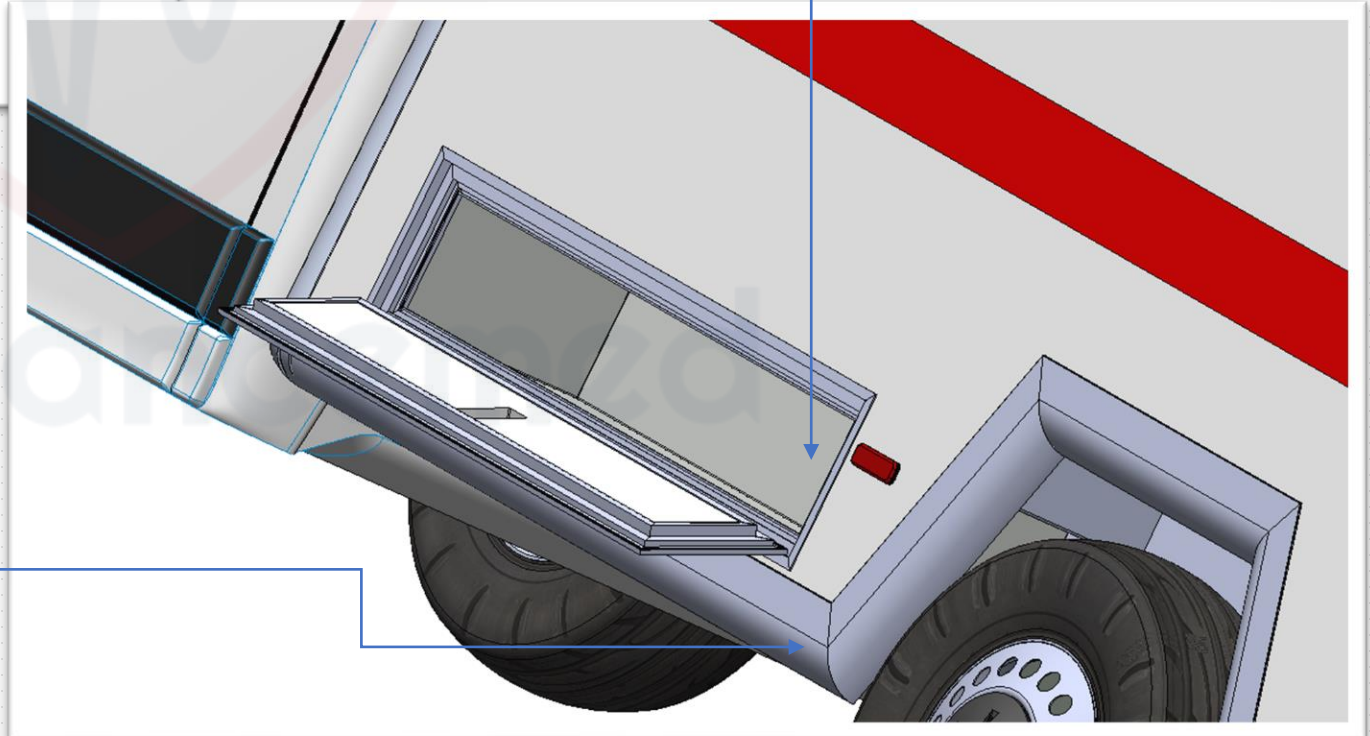

To reinforce durability and structural integrity, aluminum 5254 is utilized for the construction of corners and edges

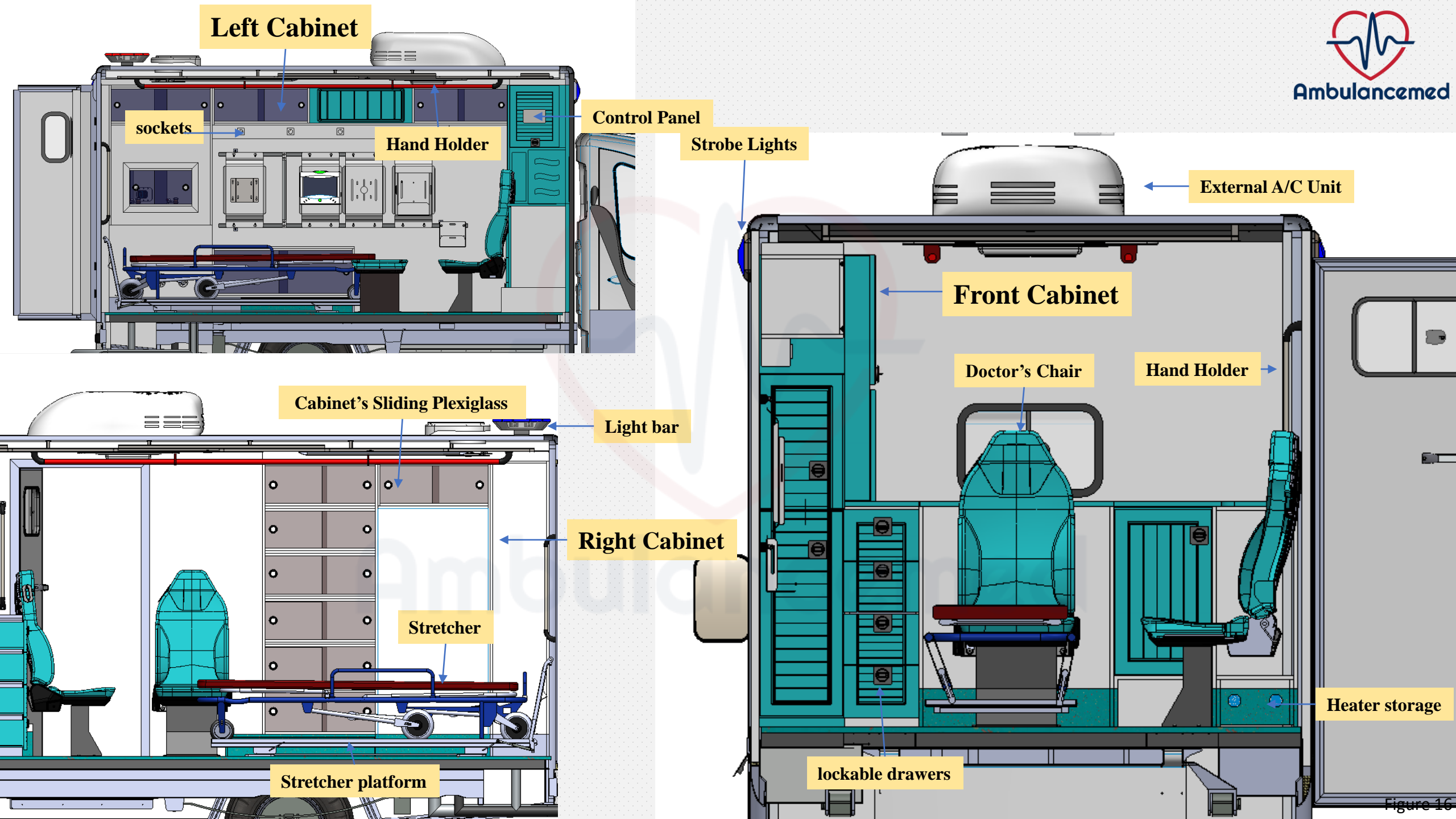

Figure 16



Ambulancemed

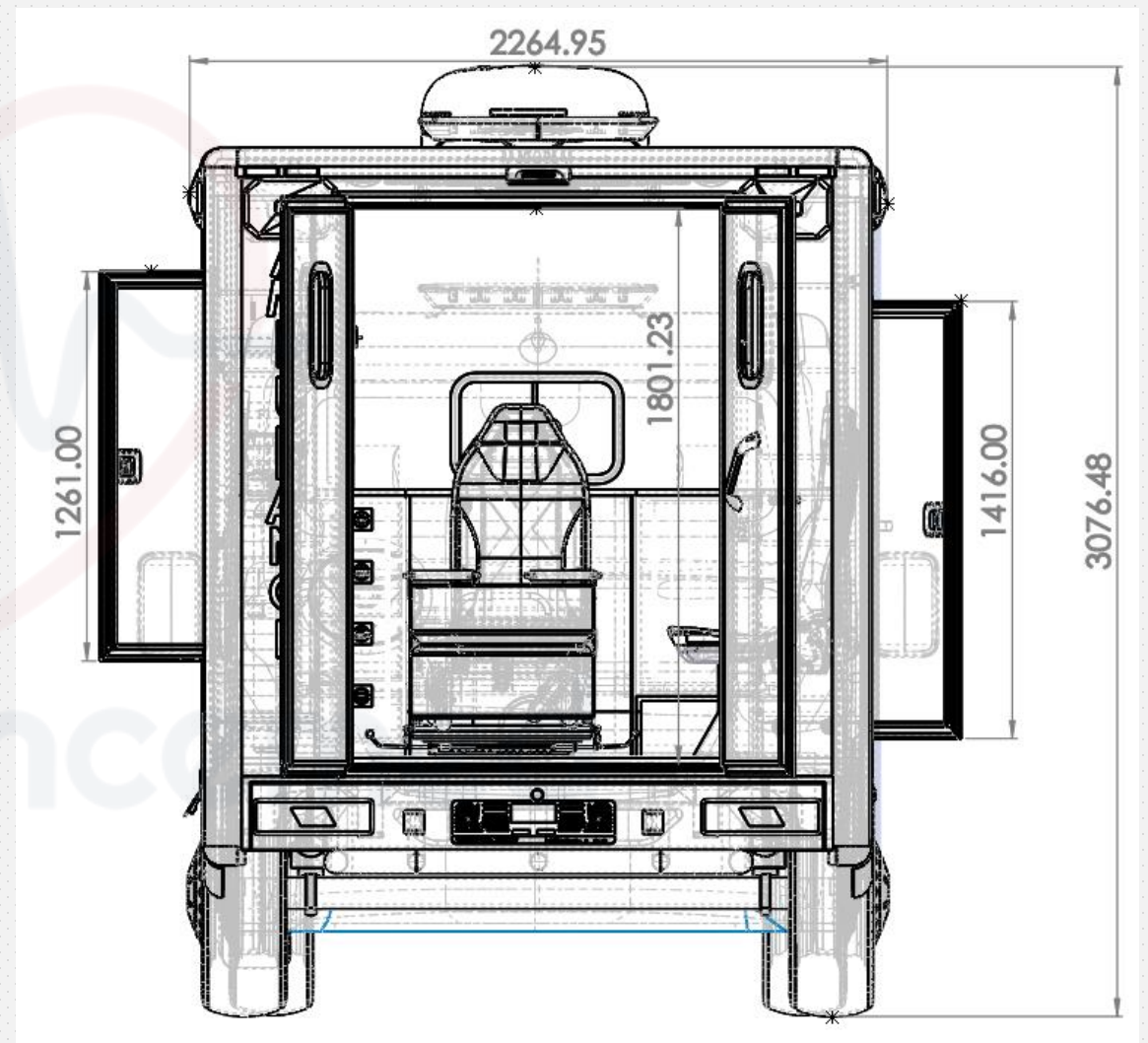
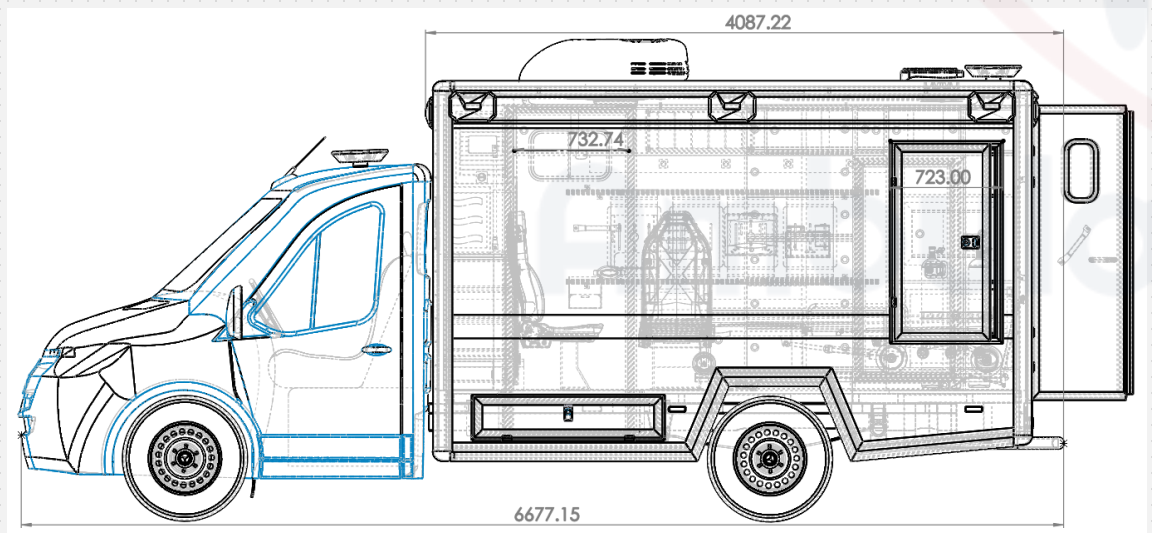
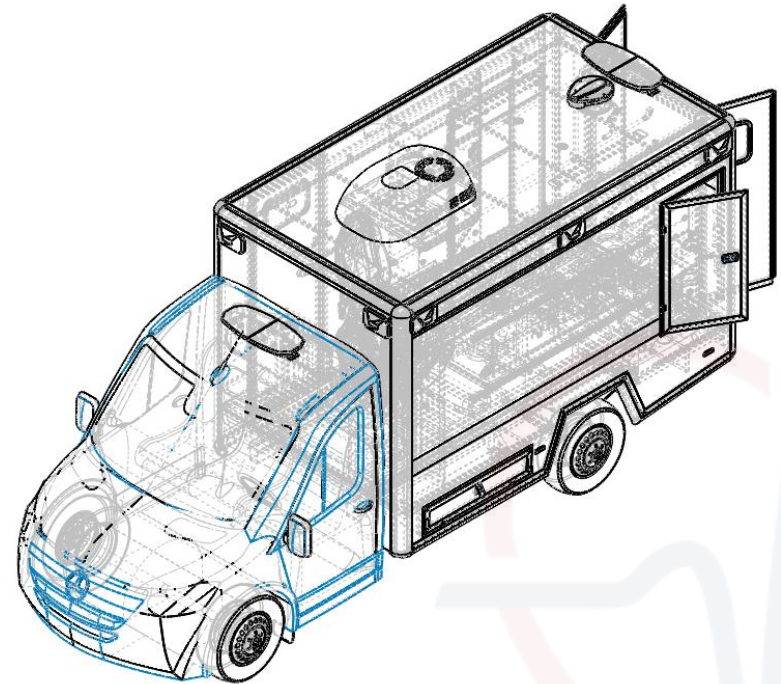

Figure 17



